

# THE INTERNATIONAL JOURNAL OF SCIENCE & TECHNOLEDGE

## High Intensity Pulsed Light Technology in Food Preservation

**Dhineshkumar V.**

Research Scholar, Department of Food Science and Technology, CFDT, Tanuvas, Chennai, India

**Dr. D. Ramasamy**

Professor and Head, Department of Food Science and Technology, CFDT, Tanuvas, Chennai, India

**C. Ashok Kumar**

M.Tech, PG Student, Department of Food Science and Technology, CFDT, Tanuvas, Chennai, India

### **Abstract:**

*With the increase in consumer awareness, demand for minimally processed foods and eco-friendliness, various technologies were developed for food processing and preservation. The conventional thermal food preservation and processing techniques appears to have the shortcoming of adversely affecting the food quality, organoleptic properties and nutrients. However, many non-thermal food preservation technologies were developed to serve the purpose. Many of such technologies are active packaging, pulsed electric field processing, high pressure processing, ultraviolet light processing and pulsed light processing. Pulsed light technology appears to be one of the best alternatives to conventional thermal and chemical decontamination process. Pulsed light processing technique has been commercialized and there have been many reports on the wide spectrum application of this technology. The technology not only decontaminates the food or packaging but also maintains its texture, nutrients etc. The germicidal effect was found to be due to photochemical and photothermal effect. It also has many other applications apart from decontamination, one such being reducing the allergen potent of some naturally occurring foods. The following review article is a compilation of reports on the mechanism of action of the technology and recent application of pulsed light processing.*

**Keywords:** High intensity, Ultraviolet light, photochemical, pulsed electric field, thermal processing

### **1. Introduction**

Pulsed light (PL) is a technique to decontaminate surfaces by killing microorganisms using short time pulses of an intense broad spectrum, rich in UV-C light. UV-C is the portion of the electromagnetic spectrum corresponding to the band between 200 and 280 nm. PL is produced using technologies that multiply the power manifold.. It is one of the emerging technologies which are used for the replacement of traditional thermal pasteurization among non thermal processes (Heinz *et al.*, 2002). It is a decontamination technique which aims at reducing the pests, spoilage microorganisms and pathogens from food without much effect on its quality (Bank *et al.*, 1990). It is recognized by several names in scientific literature i.e., Pulsed ultraviolet light (Sharma and Demirci, 2003), high intensity broad-spectrum pulsed light (Roberts and Hope, 2003), Pulsed light (Rowan *et al.*, 1999) and pulsed white light (Marquenie *et al.*, 2003).

The pulsed light processing can be described as a sterilization or decontamination technique used mainly to inactivate surface microorganisms on foods, packaging material and equipments. This technique uses light energy in concentrated form and exposes the substrate to intense short bursts of light (pulses). Typically for food processing about one to twenty flashes per second are applied.

Ultraviolet light, broad spectrum white light and near infrared light can be used for pulsed light processing (Green *et al.*, 2005). Ultraviolet-C treatment for preserving food was discovered in 1930s (Artes and Allende, 2005). Pulsed light is an improved form of ultraviolet-C that is being given to foods. It is done with the help of Xenon lamps that can produce flashes several seconds.

The following units are commonly used to characterize a PL treatment.

1. Fluence rate: is measured in Watt/meter<sup>2</sup> (W/m<sup>2</sup>) and is the energy received from the lamp by the sample per unit area per second.
2. Fluence: is measured in Joule/meter<sup>2</sup> (J/m<sup>2</sup>) and is the energy received from the lamp by the sample per unit area during the treatment.
3. Dose: used sometimes as a synonym of fluence.
4. Exposure time: length in time (seconds) of the treatment.
5. Pulse width: time interval (fractions of seconds) during which energy is delivered.
6. Pulse-repetition-rate (pr): number of pulses per second (Hertz [Hz]) or commonly expressed as pps (pulses per second).
7. Peak power: is measured in Watt (W) and is pulse energy divided by the pulse duration.

### 1.1. Principle

It is the non-thermal method of food preservation

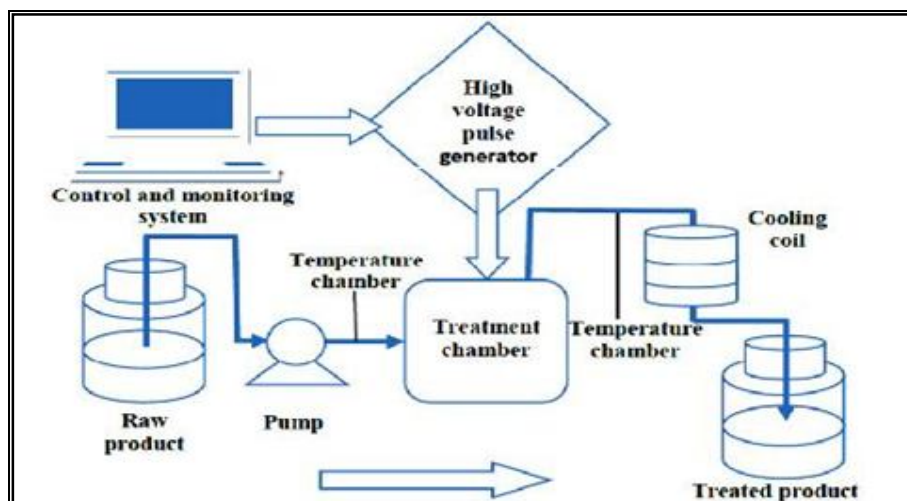

Figure 1: Flow chart of a PEF food processing system with basic component (Maged *et al.*, 2012)

that involves the generation of pulsed light with gradually increasing from low to high energy and then releasing the highly concentrated energy as broad spectrum bursts, to ensure microbial decontamination on the surface of foods and packaging foods. Within fraction of second, the electromagnetic energy gets stored in the capacitor and is then released in the form of light within a billionth of a second, which results in power amplification and minimum additional energy consumption (Green *et al.*, 2005). The inactivation efficiency of pulsed light depends upon intensity (measured in  $\text{Joule}/\text{cm}^2$ ) and the number of pulses delivered. The flow chart of pulsed electric field is shown in Figure 1.

### 1.2. Mechanism of Microbial Inactivation

The lethality of Pulsed Light may be attributed to its rich broad spectrum ultraviolet content, its short duration, high peak power and the ability to regulate the pulse duration and frequency output of flash lamps (Dunn *et al.*, 1995., Takeshita *et al.*, 2003). As a substantial portion of the Pulsed light spectrum covers ultraviolet light, it is considered that ultraviolet plays a vital role in the microbial cell inactivation. It was also found that there is no killing effect if a filter is used to remove ultraviolet (UV) wavelength region lower than 320 nm (Takeshita *et al.*, 2003). The ultraviolet spectrum comprises of three wave ranges: Long-wave ultraviolet -A (320-400 nm), Medium-wave ultraviolet -B (280-320 nm) and Short-wave ultraviolet -C (200-280 nm).

Mechanisms that have been proposed to explain the lethality of pulsed light treatment are related to ultraviolet (UV) part of the spectrum which include photochemical and photothermal effect (Anderson *et al.*, 2000; Takeshita *et al.*, 2003; Wuytack *et al.*, 2003).

The lethal effect of pulsed light can be due to photochemical or photothermal mechanism or both may exist simultaneously. However their relative importance depends on the fluence and target microorganism. The lethal effect of pulsed light was explained by most of the authors on the basis of photochemical mechanism e.g., the inactivation

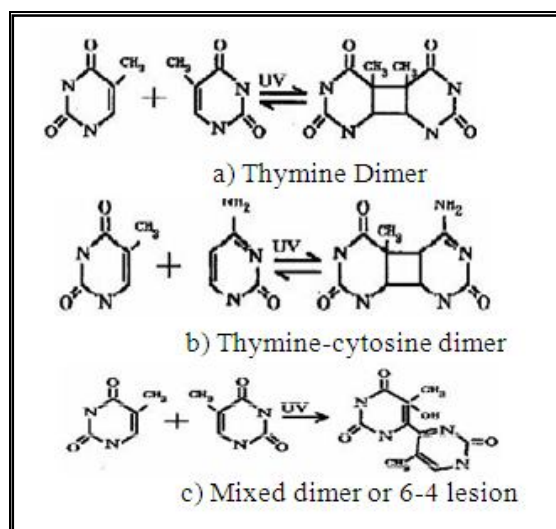

Figure 2: Formation of Thymine Dimer, Thymine-cytosine dimer and mixed dimer (Setlow *et al.*, 1966).

achieved by (Rowan *et al.*, 1999) was associated with less than 1°C rise in temperature concluded that the lethality can be attributed to the photochemical action of the shorter ultraviolet wavelengths.

The primary target cell of pulsed light in photochemical mechanism is nucleic acid as DNA is the target cell for these ultraviolet wavelengths (Chang *et al.*, 1985; Miller *et al.*, 1999). Ultraviolet light absorbed by the conjugated carbon-carbon double bonds in proteins and nucleic acids induces the antimicrobial effect as it changes the DNA and RNA structures. The bactericidal effect is attributed to the high energy short wave ultraviolet-C range. In the ultraviolet-C range of 250-260 nm, alterations in DNA take place due to pyrimidine dimers mainly thymine dimers (Mitchell *et al.*, 1992; Giese and Darby, 2000). Ultraviolet irradiation usually generates thymine dimers in large quantity, cytosine dimers in low quantity and mixed dimers at an intermediate level as shown in Figure 2 (Setlow *et al.*, 1966). These dimers inhibit the formation of new DNA chains in the process of cell replication resulting in the chologenic death of affected microorganisms by ultraviolet (Bolton and Linden, 2003). The ultraviolet-C treatment of bacterial spores may result in the formation of spore photo-product 5-thyminy-5, 6-dihydrothymine and in single-strand breaks, double-strand breaks and cyclobutane pyrimidine dimers (Slieman and Nicholson, 2000). It was also found by experiments that enzymatic repair of DNA does not occur after damaged by pulsed light.

The lethal effect of Pulsed light can also be due to photothermal effect. Wekhof (2000) proposed that with a fluence exceeding 0.5 Joule/cm<sup>2</sup>, the disinfection is achieved through a rupture of bacteria during their temporary overheating caused by absorption of all ultraviolet light from a flash lamp. This hypothesis become evident by (Wekhof *et al.*, 2001) when they showed electron-microscope photographs of flashed *Aspergillus niger* spores presenting severe deformation and rupture. The ruptured top of spore become evident of an escape of an overheated content of the spore, which became empty after such an internal “explosion” and “evacuation” of its content took place during the light pulse.

Other effects on the cells include, collapse of cell structure, enlargement of vacuoles as found in some microbial studies (Proctor, 2011) as showed by flashed yeast cells. Antimicrobial effects are also manifested due to changes in ion flow, increased cell membrane permeability and depolarization of cell membrane (Ohlsson and Bengtsson, 2002). As Pulsed light causes cell membrane damage, it could be considered as a technique for sterilization (Takeshita *et al.*, 2003, Bialka *et al.*, 2008).

### 1.3. Factors Affecting the Microbial Inactivation by Pulsed Light

#### 1.3.1. Type of Micro-Organism

Optical properties of cells, for example their degree of scattering and absorption of light are important. The incident beam of light undergoes refraction due to difference in the optical density between the substrate and the surrounding air. There are also some microorganisms resistant to pulsed light (Ethan, 2009; Rajkovic *et al.*, 2010; Manzocco *et al.*, 2011; Uysal and Kirca, 2011).

#### 1.3.2. Interaction between Light and the Substrate or Between Light and the Microbial Cells (Micro-Organism)

This factor is very important from the point of view of the efficacy of the pulsed light treatment.

The composition of the medium and the wavelength of the incident light decide the reflection, refraction, scattering and absorbing of the light, the refraction and reflection of light being vital for surface treatments. For transparent and coloured food materials, refraction is particularly relevant, whereas for opaque food materials, reflection is the prevailing phenomenon. Specular or diffused reflection can occur depending on the smoothness or roughness of the surface of the material respectively. For smooth surfaces, the incident light bounces on the surface and comes out at the same angle as the incident beam, with the same spectral distribution of energy, which is termed as specular reflection. For rough surfaces, light travels through the outer layers of the material, where the incident light is partly absorbed, this phenomenon is called diffuse reflection. The absorption at different wavelengths is different and hence the resulting spectral distribution of incident and the diffused light coming out is in all directions

(Duran and Calvo, 2002), and reflection of light can tend to decrease the efficiency of the pulsed light treatment. For translucent materials, some part of the incident light interacts with the internal structures

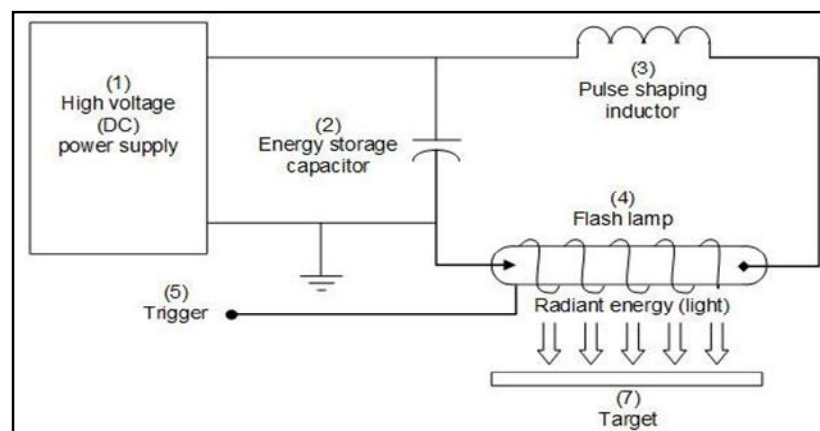

Figure 3: Functional diagram of a high-intensity pulsed-light system. (Adapted from Xenon Corp., 2005)

and causes multiple internal reflections, redirections which result into scattering. In the case of biological tissues, absorption and scattering are the most relevant types of light–substrate interaction (Cheong *et al.*, 1990).

### 1.3.3. The Distance from the Light Source

As the distance from light source and depth of the substrate increases, the absorption and scattering diminishes. This is because the light intensity decreases as it travels through the substrate. The quantitative distribution of light dose inside a substrate is described by the term Optical penetration depth, which represents the distance over which light decreases in fluence rate to 37% of its initial value.

The optical penetration varies with wavelength, with shorter wavelengths providing deeper penetration into the food than longer wavelengths (Dagerskog and Osterstrom, 1979).

### 1.3.4. Design of Pulsed Light System

Pulsed-light equipment may vary from manufacturer to manufacturer. The system of pulsed light consists of several common components as shown in Figure 3. 1) A high voltage power supply: provides electrical power to the storage capacitor 2) A storage capacitor: which stores electrical energy for the flash lamp 3) A pulse-forming network: determines the pulse shape and spectrum characteristics 4) The gas discharge flash lamp 5) A trigger signal: which initiates discharging of the electrical energy to the flash lamp, which is the key element of a pulsed light unit.

The flash lamp is the important element of any Pulsed light unit that converts 45% to 50% of the input electrical energy to pulsed radiant energy

(Xenon Corp., 2005). This is filled with an inert gas such as xenon or krypton. Xenon is mostly preferred because of its higher conversion efficiency and also because it is a gas of choice for most of the microbial inactivation applications. The envelope, the seals and the electrodes are the main structural components of the flash lamp, the envelope being a jacket that contains the filling gas and also surrounds the electrodes. The envelope must be transparent to the radiations that are emitted by the lamp, be impervious to the filling gas as well as air, must be able to withstand high temperatures and thermal shocks and have mechanical strength. The envelopes are typically made out of clear fused quartz, called suprasil, of about 1 millimetre thickness. Metallic electrodes protrude into each end of the envelope and are connected to the capacitor which is charged to a high voltage. The electrodes provide electric current into the gas. The lifetime of the lamp is determined by the cathode and is hence an important component. The operational requirements decide the material of making of the electrode. The duty of the cathode is to provide unspattered and adequate amount of electrons, because sputtering, caused due to hot spots created during peak power supply, may lead to corrosion of the cathode material. This in turn would reduce the lifetime of the cathode. The anode should have sufficient mass or surface area to sustain the loading of power caused by the electron bombardment from the electric arc. The whole assembly of the flash lamp needs to be sealed. Commonly used seals include, solder seals, rod seals and ribbon seals.

The gas in the flash lamp undergoes ionisation when subjected to a high voltage, high-current electrical pulse and plasma formation takes place near the anode by the electrons travelling towards it. A very large current pulse formation occurs and this is sent through the ionized gas, exciting the electrons surrounding the gas atoms, causing them to jump to higher energy levels. The electrons while jumping back to their lower energy levels, release quanta of energy producing photons. Overheating problems are encountered during this operation and hence cooling devices are to be provided for long lamp life and undeviating operation. Cooling fans can be used to serve the purpose.

Other pulsed light sources are explored such as solid state Marx-generator for pulsing an ultraviolet lamp in microbial inactivation applications, static discharge lamps with spectral outputs similar to flash lamps and sparker technology which generates a light and sonic sound pulse (Proctor, 2011).

Adjustable one or more flash lamp units, a power unit and a high voltage connection that allows a high electric pulse transfer are used to produce the pulsed light. The current passing through the gas chamber of the flash lamp unit emits a short intense burst of light.

There are numerous patented equipments and are designed to control unique treatment and are product specific (Green *et al.*, 2005).

The high current discharge through gas filled flashlights results in millisecond flashes of broad spectrum white light, about 20,000 times more intense than sunlight. Conversion efficiency of electricity to light is about 50%. The spectral distribution is 25% ultraviolet, 45% visible light and 30% infrared. The rate of flashes is 1-20 flashes/sec, a few flashes being generally sufficient for the pasteurizing or sterilizing treatment. This means that the treatment time is very short and throughput is high. Depending on the application, wavelengths that would adversely affect food flavour or quality are filtered off.

The flashlights are arranged in arrays, adapted to the particular application, be it the continuous sterilisation of packaging film in aseptic processing, the sterilisation on-line of transparent liquids or the surface pasteurisation of solid foods in plastic packaging. Most plastic packaging materials transmit broadband light well, exceptions being Polyethylene terephthalate (PET), polycarbonate, polystyrene and polyvinyl chloride (PVC). For complex surfaces, such as those of foods like meat and fish, it will be difficult to illuminate or reach all parts of the surface to obtain a sterilising effect (Ohlsson and Bengtsson, 2002).

The type of equipment for food preservation depends on some factors such as ozone build-up, surface area of food product and dimensions of each treatment unit and desired degree of decontamination. A cooling unit facility maybe required in the case of a food under treatment is temperature sensitive (Green *et al.*, 2005).

Pulsed light systems can be of either batch or continuous type depending on the usage. In the case of batch processing, such as those developed by Xenon Corp. (Waltham, MA), the packets are placed in a chamber with lamps located along the walls of the chamber.

The simplest designs include a single lamp located above the sample and an adjustable tray to hold the samples. More complex designs may incorporate up to eight lamps within a chamber along with a quartz stand to hold the sample and allow a 360° exposure and treatment. In the case of continuous processing, the packaged or unpacked products are placed on conveyor belts, on spool bars and in tunnels and then passed through chamber with lamps (Proctor, 2011). An in-line treatment system is possible with such an assembly. Experiments with continuous pulsed light have been performed. These were for milk decontamination (Krishnamurthy *et al.*, 2007) and for various fruit juices (Palgan *et al.*, 2011; Pataro *et al.*, 2011).

For all existing pulsed-light systems, a control system is used to automate the process and control the rate of pulsing. Optical sensors can be installed to record the output of the entire unit. The newest generation of SteriPulse™ - XLR systems sold by Xenon Corp. are equipped with a LiteMark light monitor. This system contains a photoelectric detector module installed in the treatment chamber that senses the light intensity from each flash, which is scattered sideways in the lamp housing window, and relates it to the side-scattered intensity produced by a new lamp. This enables the operator to monitor in real time the performance of a lamp system and to make decisions regarding the lamp replacements prior to the lamp output reaching a predetermined minimal level.

#### 1.4. Applications

##### 1.4.1. Pulsed Light Treatment Given to Eggs for Surface Decontamination

associated with	salmonellosis	outbreaks	caused
by <i>Salmonella</i>	Enteritidis in	the United	States

Table 1

Eggs and egg-based products were frequently of America (U.S.A.), as well as in the European Union (E.U.) (Braden, 2006; EFSA, 2007). This is a potential consequence of the high frequency at which *Salmonella* Enteritidis colonizes the ovaries of laying hens (Gantois *et al.*, 2008)

Eggs were treated with pulsed light of flashes of 2.1 Joule/cm<sup>2</sup> and 10.5 Joule/cm<sup>2</sup>. Exposure to 2.1 Joule/cm<sup>2</sup> leads to death of *Salmonella* cells (5 log colony-forming units (CFU) per egg shell) on the egg surface with slight increase in temperature. Increase to 10.5 Joule/cm<sup>2</sup> did not cause penetration of *Salmonella* cells to the egg contents from the shell. No adverse effect on quality of egg albumin was observed. No effect on sensory and functional properties (Lasagabster *et al.*, 2011). Another study for inactivation of *Salmonella enteritidis* was performed that involved usage of pulsed light treatment of 0.5 Joule/cm<sup>2</sup> to 0.7 Joule/cm<sup>2</sup>. Treatment of 0.5 Joule/cm<sup>2</sup> gave an inactivation of 6.7 log colony-forming units (CFU)/cm<sup>2</sup> on noble agar. Different results were obtained based on the state of the cuticle. In case of unwashed eggs, the highest decontamination of 3.6 log colony-forming units (CFU)/egg was observed and for washed eggs, highest decontamination of 1.8 log colony-forming units (CFU)/egg was observed. The integrity of the cuticle is maintained and hence this technique could be used in egg processing (Hierro *et al.*, 2009).

##### 1.4.2. Shelf-Life Extension and Inactivation of *Listeria Monocytogenes* on Ready to Eat Cooked Meat Products Using Pulsed Light

*Listeria monocytogenes* is responsible for severe foodborne disease outbreak. Processed meats are well documented to be a potential vehicle for human listeriosis. Vacuum packaged ham and bologna slices were artificially inoculated with *Listeria monocytogenes* and then treated with pulsed light with fluences of 0.7, 2.1, 4.2 and 8.4 Joule/cm<sup>2</sup>. It was found to reduce the microbial load of ham by 1.78 colony-forming units (CFU)/cm<sup>2</sup> and of bologna slices by 1.11 colony-forming units (CFU)/cm<sup>2</sup> (Hierro *et al.*, 2011). The lower inactivation obtained on bologna could be explained by the distinct microstructural features of both products. It is well known that the surface topography greatly influences the efficacy of pulsed light treatment (Woodling and Moraru, 2005). It tripled the shelf-life of ham as compared to conventional ready-to-eat (RTE) products. 2.1 Joule/cm<sup>2</sup> adversely affected the sensory quality of bologna slices (Hierro *et al.*, 2011).

##### 1.4.3. Pulsed Light Treatment for Decontamination of Chicken from Food Pathogens

High-power pulsed light of 1,000 pulses, treatment duration 200 seconds and total ultraviolet light dose 5.4 Joule/cm<sup>2</sup> was found to reduce viability of *Salmonella typhimurium* and *Listeria monocytogenes* inoculated on the surface of chicken by 2-2.4 log<sub>10</sub> (N/NO) colony-forming units (CFU)/ ml (Paskeviciute *et al.*, 2011). Also, the total aerobic mesophiles on the surface of meat were diminished by 2 log<sub>10</sub> (N/NO) colony-forming units (CFU)/milliliter. Nonthermal conditions were maintained throughout (<42°C). The intensity of lipid peroxidation in control and treated chicken samples differed in 0.16 milligram (mg) malondialdehyde per kilogram of chicken meat. Organoleptic properties of treated chicken did not detect any changes of raw chicken, chicken broth or cooked chicken meat when it was treated under nonthermal conditions in comparison with control (Paskeviciute *et al.*, 2011).

##### 1.4.4. Pulsed Light Treatment for Freshly Cut Mushroom

Fresh slices of mushrooms were exposed to pulsed light treatment by flashing at 4.8, 12 and 28 Joules/cm<sup>2</sup> and it was found to increase the shelf life by 2-3 days in comparison to untreated samples.

The native microflora reduction ranged from 0.6-2.2 log after 15 days of refrigeration. 12 and 28 Joule/cm<sup>2</sup> treatment affected the texture due to thermal damage by treatment. It induced enzymatic browning due to increase in polyphenoloxidase activity. Some phenolic compounds and vitamin C content were found to be reduced. But 4.8 Joule/cm<sup>2</sup> increased shelf-life without affecting the texture and antioxidant properties (Oms-Oliu *et al.*, 2010).

#### 1.4.5. Continuous Flow Pulsed Light System for Bacterial Inactivation in Fruit Juices and Milk

Apple juice (pH of 3.49) and orange juice (pH of 3.78) were inoculated with gram positive (*Listeria innocua* 11288) and gram negative (*Escherichia coli* DH5-*a*) bacteria. These were then subjected to continuous pulsed light system. Xenon-flash lamp emitting light in the range of 100-110 nanometre (nm) and with the flashes at constant frequency of 3 Hertz and lasting for 360 microseconds ( $\mu$ s) was used. It was concluded that the lethal effect of pulsed light processing depends on the type of microorganism and the absorption properties of the liquid food. With treatment of 4 Joule/cm<sup>2</sup>, the microbial load reductions in apple and orange juices for *Escherichia coli* were 4.00 and 2.90 Log-cycle respectively and for *Listeria innocua* were 2.98 and 0.93 Log-cycles respectively (Pataro *et al.*, 2011).

Continuous flow pulsed light technique was also used for inactivation of *Staphylococcus aureus* in milk and has a potential in treatment of milk pathogens (Krishnamurthy *et al.*, 2007) carried out measurements of the temperature increase during the pulsed light treatment of milk in a continuous flow system. Milk temperature increased up to 38°C, depending on the residence time as well as the distance of the product from the light source. This temperature increase caused a fouling effect as well as possible changes in milk quality.

#### 1.4.6. Decontamination of Food Powders Using Pulsed Ultraviolet (UV) Light

Food powders were decontaminated using pulsed ultraviolet (UV) light and the treatment parameters were optimized. 58 Joule/cm<sup>2</sup> of pulsed light was required for *Saccharomyces cerevisiae* decontamination and reducing the microbial load by 7 log. It was found that the thermal effect rather than the Ultraviolet (UV) effect of pulsed light worked for decontamination of coloured powders (Fine and Gervais, 2004).

#### 1.4.7. Decontamination of Packaging Material

Paper-polyethylene was artificially inoculated with spores such as *Cladosporium herbarum*, *Aspergillus niger*, *Aspergillus repens* and *Aspergillus cinamomeus* and then exposed to pulsed light with fluence ranging from 0.244 to 0.977 Joule/cm<sup>2</sup>. The highest level of inactivation of 2.7 log reduction was achieved. The colour of the spores affected their resistance to pulsed light. Different spores required different fluences for their inactivation (Turtoi and Nicolau, 2007).

#### 1.4.8. Application on Food Processing Equipment

Pulsed ultraviolet (UV) light treatment was studied for its applicability in decontamination of the stainless steel surface contacting meat from *Listeria monocytogenes* and *Escherichia coli* O157:H7. A four lamp batch scale apparatus which generated 3 Joule/cm<sup>2</sup> with an input voltage of 3000 Volts was used. The study was performed on stainless steel slicing knife. The type of meat product in contact with the treatment surface and the time between contamination and intense pulse treatment decide the effectiveness of the microbial inactivation. When the knife surface was in contact with meat product containing lower fat and protein content and the time between contamination and treatment was 60 seconds, highest effectiveness of inactivation of 6.5 log colony forming units (CFU)/side of knife was achieved. It was also observed that even though the number of flashes was increased to compensate for the extended time between contamination and treatment, the lost effectiveness of microbial inactivation could not be restored (Rajkovic *et al.*, 2010).

#### 1.4.9. Pulsed Light Field Technology in Combination with Other Non-Thermal Processing Technologies

Pulsed light technology in combination with other non-thermal processing technologies was experimented on a blend of apple and cranberry juice and the efficacy of the combination of technologies was determined on the basis of quality attributes such as odour and flavour. The non-thermal technologies studied were, ultra-violet light (5.3 Joule/cm<sup>2</sup>), high intensity pulsed light (3.3 Joule/cm<sup>2</sup>), pulsed electric field processing (34 kilovolt/cm, 18 Hertz, 93 microsecond) and manothermosonication (5 bar, 43°C, 750 Watt, 20 kilohertz). A blend of apple and cranberry juice in the ratio of 90:10 (volume/volume) was taken and stored at -20°C pre- and post processing.

The juice was filtered through 425 micrometre ( $\mu$ m) steel sieve and then processed. The above mentioned processes were paired, their combinations were analysed. A light based technology (ultra violet or high intensity light pulses) in combination with pulsed electric field or manothermosonication was applied. It was concluded that ultraviolet and pulsed electric field combination or high intensity light pulses and pulsed electric field combination was found to maintain product quality better than any combination with manothermosonication under the applied conditions which lead to adverse effects on product quality (Caminiti *et al.*, 2011a).

High intensity light pulses in combination with pulsed electric field were used to inactivate *Escherichia coli* in apple juice. The optimum combination was obtained and sensory analysis was performed as well for quality effects. The optimum combination did not affect the quality (Caminiti *et al.*, 2011b).

High intensity light pulses in combination with thermosonication were experimented for inactivation of *Escherichia coli* in orange juice could be developed as hurdle technology. Individual as well as combination of the techniques were studied and inactivation from 2.5 to 3.93 log colony forming units (cfu) ml<sup>-1</sup> was achieved (Munoz *et al.*, 2011).

Using naturally occurring antimicrobial substances in combination with the novel techniques of processing such as pulsed light processing can provide new avenues in controlling pathogenic bacteria and thus improve safety and quality of food (Galvez *et al.*, 2010).

#### 1.4.10. Mitigation of Allergen Using Pulsed Ultraviolet Light

Peanut allergy is a severe Immunoglobulin E mediated reactions with food. Peanut allergy can be prevented by complete avoidance. But pulsed ultraviolet light treatment of peanut extracts and peanut butter showed to deactivate Ara h 2, the most potent allergic protein present in peanut. Protein band intensity for Ara h1, Ara h2, Ara h3 reduced at energy levels ranging from 111.6 – 223.2 Joule/cm<sup>2</sup> (Yang *et al.*, 2011).

Pulsed ultraviolet light treatment of soy extracts has found to decrease the levels of soy allergens (glycinin,  $\beta$ -conglycinin). But clinical data are needed for development of products from such treated soy extracts (Yang *et al.*, 2010).

#### *1.5. Advantages and Disadvantages*

##### 1.5.1. Advantages

The intensity of light, that lasts for only a second, is 20,000 times brighter than sunlight, but there is no thermal effect, so quality and nutrient content are retained (Brown, 2008). The xenon-flash lamps used in pulsed light treatment are more eco-friendly than the mercury vapour lamps used in ultraviolet (UV) treatment (Gomez-Lopez *et al.*, 2007). Pulsed white light is not strictly a non-thermal, but the thermal action, due to its very short duration; it doesn't show much adverse effect on the nutrients (Ohlsson and Bengtsson, 2002).

##### 1.5.2. Disadvantages

A possible problem of this preservation method is that folds or fissures in the food may protect microbes from being exposed to the pulsed light (Brown, 2008). There might be some strains of micro-organisms which are resistant to the pulsed light treatment, for example *Listeria monocytogenes* (Caminiti *et al.*, 2011a). This technique for decontamination of micro-organisms is useful mostly in case of liquid foods and surface of solid foods and hence limiting its application.

##### 1.5.3. Packaging Material Requirements

The packaging materials for irradiation should be chemically stable, for example, they should not undergo depolymerisation or significant changes in elastic modulus. The material should be transparent in order to allow the light to pass into the food. Due to the low-temperatures of operation or treatment, the packaging system does not require high melting temperature for heat seal, so cold sealing using adhesives can be performed. This leads to less volatile odour production generally associated with burning of plastic, additives and printing solvent. This low temperature sealing is also beneficial to high fat and frozen foods. The packaging material thus, is chosen on the basis of its stability to the treatment, consumer acceptance and regulations (Han, 2007).

## **2. Conclusion**

The pulsed light processing is a new concept and has many applications in the food industry as a non-thermal technique of food preservation. While developing the applications of pulsed light processing, it is to be taken into consideration that the food to be processed, the microbial type and load affect the efficacy of the treatment. Though with some limitations, if complemented with other processing techniques this technology can help in better food preservation with minimal effects on the food quality. There are some microbial species resistant to the pulsed light processing technique and so such species should be studied and also the foods they contaminate be considered separately for processing. This technique has shown potent in reducing peanut allergy. It can be further studied to reduce other allergies associated with food. This technique, being still new and hardly commercialized should be researched for economization.

## **3. References**

1. Anderson, J. G., Rowan, N. J., MacGregor, S. J., Fouracre, R. A. and Farish, O. 2000. Inactivation of food-borne enteropathogenic bacteria and spoilage fungi using pulsed-light. *IEEE Transactions on Plasma Science* 28: 83-88.
2. Angersbach, A., Heinz, V. and Knorr, D. 2000. Effects of pulsed electric fields on cell membranes in real food systems. *Innovative Food Science and Emerging Technologies* 1(2): 135-149.
3. Artes, F. and Allende, A. 2005. Processing lines and alternative preservation techniques to prolong the shelf life of minimally processed leafy vegetables. *European Journal of Horticultural Science* 70: 231-245.
4. Bank, H. L., John, J., Schmehl, M. and Dracht, R .K. 1990. Bactericidal effectiveness of Modulated Ultraviolet Light. *Applied and Environmental Microbiology* 60: 3888-3889.
5. Bialka, K. L., Demirci, A. and Puri, V. M. 2008. Modelling the inactivation of *Escherichia coli* O157:H7 and *Salmonella enterica* on raspberries and strawberries resulting from exposure to ozone or pulsed Ultraviolet light. *Journal of Food Engineering* 85: 444-449.
6. Bolton, J. R. and Linden, K. G. 2003. Standardization of methods for fluence (Ultraviolet dose) determination in bench-scale Ultraviolet experiments. *Journal of Environmental Engineering* 129: 209-215.
7. Braden, C. R. 2006. *Salmonella enterica* serotype Enteritidis and eggs: A national Epidemic in the United States. *Clinical Infectious Diseases: an official publication of the Infectious Diseases Society of America* 43: 512–517.
8. Brown, A. C. 2008. *Understanding Food: Principles and Preparation*. In Brown, A.C. (3<sup>rd</sup> Eds). Belmont, CA: Thompson/Wadsworth publishing, p. 47.
9. Caminiti, I. M., Noci, F., Munoz, A., Whyte, P., Morgan, D. J. and Cronin, D. A. 2011a. Impact of selected combinations of

- non-thermal processing technologies on the quality of an apple and cranberry juice blend. *Journal of Food Chemistry* 124: 124 (144) 1387-1389.
10. Caminiti, I. M., Palgan, I., Noci, F., Munoz, A., Whyte, P., Cronin, D. A., Morgan, D. J. and Lyng, J. G.
  11. 2011b. The effect of pulsed electric fields (PEF) in combination with high intensity light pulses (HILP) on *Escherichia coli* and quality attributes in apple juice. *Innovative Food Science and Emerging Technologies* 12 : 118-123.
  12. Chang, J. C., Ossoff, S.F., Lobe, D.C., Dorfman, M.H., Dumais, C.M., Qualls, R.G. and Johnson, J.D.
  13. 1985. Ultraviolet (UV) inactivation of pathogenic and indicator organisms. *Applied Environmental Microbiology* 49: 1361-1365.
  14. Cheong, W., Prael, S.A. and A. J. Welch. 1990. A review of the optical properties of biological tissues. *IEEE Journal of Quantam electronics* 26 (12): 2166–2185.
  15. Dagerskog, M. and Osterstrom, L. 1979. Infra-red radiation for food processing I: A study of the fundamental properties of infra-red radiation. *Lebensmittel-Wissenschaft u. and Technologie* 12: 237–242.
  16. Dunn, J., Ott, T. and Clark, W. 1995. Pulsed light treatment of food and packaging. *Food Technology* 49 (9): 95-98.
  17. Duran, L. and Calvo, C. 2002. Optical properties of foods. In *Encyclopedia of life support systems*. UNESCO-EOLSS Publishers Oxford, available online at <http://www.eolss.net>.
  18. EFSA. 2007. Report of the task force on zoonoses data collection on the analysis of the baseline study on the prevalence of *Salmonella* in holdings of laying hen flocks of *Gallus gallus*. *European Food safety Authority Journal (EFSA)* 97: 1–84.
  19. Ethan, S. 2009. The Produce Contamination Problem: Causes and Solutions. In Gerald M. S., Matthews, K. R. (Eds), p. 280. Academic Press.
  20. Fine, F. and Gervais, P. 2004. Efficiency of pulsed ultraviolet light for microbial decontamination of food powders. *Journal of Food Protection* 67 : 787-792.
  21. Galvez, A., Abriouel, H., Benomar, N. and Lucas, R. 2010. Microbial antagonists to food borne pathogens and biocontrol. *Current Opinion in Biotechnology* 21: 142-148.
  22. Gantois, I., Eeckhaut, V., Pasmans, F., Haesebrouck, F., Ducatelle, R. and Van Immerseel, F. 2008.
  23. A comparative study on the pathogenesis of egg contamination by different serotypes of *Salmonella*. *Avian Pathology* 7(4): 399–406.
  24. Giese, N. and Darby, J. 2000. Sensitivity of microorganisms to different wavelengths of ultraviolet (UV) light: implications on modeling of medium pressure ultraviolet (UV) systems. *Water Research* 34: 4007- 4013.
  25. Gomez-Lopez, V. M., Ragaerta, P., Debevere, J. and Devlieghere, F. 2007. Pulsed light for food decontamination: A review. *Trends in Food Science and Technology* 18: 464-473.
  26. Green, S., Basaran, N. and Swanson, B. 2005. Food preservation techniques. In Zenthen, P. and Bogh-Sorenson, L. (Eds). Washington, United States of America: Woodhead Publishing House, p. 365 CRC press.
  27. Han, J. H. 2007. Packaging for non-thermal processing of food. In Han, J. H. (illustrated Ed). Oxford, United Kingdom: John Wiley and Sons, p. 490 IFT Press series.
  28. Heinz, V., Alvarez, I., Angersbach, A. and Knorr, D. 2002. Preservation of liquid foods by high intensity pulsed electric fields – basic concepts for process design. *Trends in Food Science and Technology* 12: 103–111.
  29. Hierro, E., Barroso, E., de la Hoz, L., Ordonez, J. A., Manzano, S. and Fernandez, M. 2011. Efficacy of pulsed light for shelf-life extension and inactivation of *Listeria monocytogenes* on ready-to-eat cooked meat products. *Innovative Food Science and Emerging Technologies* 12 : 275-281.
  30. Hierro, E., Manzano, S., Ordonez, J. A., de la Hoz, L. and Fernandez, M. 2009. Inactivation of *Salmonella enterica* serovar Enteritidis on shell eggs by pulsed light technology. *International Journal of Food Microbiology* 135 (2) : 125-130.
  31. Krishnamurthy, K., Demirci, A. and Irudayaraj, J. M. 2007. Inactivation of *Staphylococcus aureus* in milk using flow-through Pulsed ultraviolet light treatment System. *Journal of Food Science* 72 : 233-239.
  32. Lasagabster, A., Arbolea, J. C. and Martinez, D. M. 2011. Pulsed light technology for surface decontamination of eggs, Impact on *Salmonella* inactivation and egg quality. *Innovative Food Science and Emerging Technologies* 12 (2): 124-128.
  33. Maged, E. A., Mohamed. and Ayman, H. A. E. 2012. Pulsed Electric Fields for Food Processing Technology. This is an open access chapter distributed under the terms of the creative commons Attribution License, available online at <http://www.intechopen.com/download/get/type/pdfs/id/38363>.
  34. Manzocco, L., Da Pieve, S. and Maifreni, M. 2011. Impact of ultraviolet (UV)-C light on safety and quality of fresh-cut melon. *Innovative Food Science and Emerging Technologies* 12: 13-17.
  35. Marquenie, D., Geeraerd, A. H., Lammertyn, J., Soontjens, C., Van, I. J. F., Michiels, C. W. and Nicolai, B. M. 2003.
  36. Combinations of pulsed white light and Ultraviolet-C or mild heat treatment to inactivate conidia of *Botrytis cinerea* and *Monilia fructigena*. *International Journal of Food Microbiology* 85: 185-196.
  37. Miller, R., Jeffrey, W., Mitchell, D. and Elasri, M. 1999. Bacterial response to ultraviolet light. *American Society for Microbilology (ASM) News* 65:535-541.
  38. Mitchell, D. L., Jen, J. and Cleaver, J. E. 1992. Sequence specificity of cyclobutane pyrimidine dimers in DNA treated with solar (ultraviolet B) radiation. *Nucleic Acids Research* 20: 225-229.
  39. Munoz, A., Palgan, I., Noci, F., Morgan, D. J., Cronin, D. A., Whyte, P., and Lyng, J. G. 2011. Combinations of High intensity light pulses and thermosonication for the inactivation of *Escherichia coli* in orange juice. *Food Microbiology* 28: 1200-1204.



40. Ohlsson, T. and Bengtsson, N. 2002. Minimal processing technologies in the food industry. In Ohlsson, T. and Bengtsson, N. (Eds). Cambridge, England: Woodhead Publishing, p. 112. CRC Presss.
41. Oms-Oliu, G., Aguilo-Aguayo, I., Martin-Belloso, O. and Soliva-Fortuny, R. 2010. Effects of pulsed light treatments on quality and antioxidant properties of fresh-cut mushrooms (*Agaricus bisporus*). *Postharvest Biology and Technology* 60 (3): 216-222.
42. Palgan, I., Caminiti, I. M., Munoz, A., Noci, F., Whyte, P., Morgan, D. J., Cronin, D. A. and Lyng, J. G. 2011. Effectiveness of High Intensity Light Pulses (HILP) treatments for the control of *Escherichia coli* and *Listeria innocua* in apple juice, orange juice and milk. *Food Microbiology* 28 (1): 14-20.
43. Paskeviciute, E., Buchovec, I. and Luksiene, Z. 2011. High Power Pulsed light for decontamination of chicken from food pathogens: A study on antimicrobial efficiency and organoleptic properties. *Journal of Food Safety* 31 : 61-68.
44. Pataro, G., Munoz, A., Palgan, I., Noci, F., Ferrari, G. and Lyng, J. G. 2011. Bacterial inactivation in fruit juices using a continuous flow Pulsed Light (PL) system.
45. *Food Research International* 44: 1642-1648. Proctor, A. 2011. Alternatives to Conventional Food Processing. In Proctor, A. (Ed). Arkansas, USA: Royal Society of Chemistry (RSC), p. 200.
46. Rajkovic, A., Tomasevic, I., Smigic, N., Uyttendaele, M., Radovanovic, R. and Devlieghere, F. 2010. Pulsed ultraviolet light as an intervention strategy against *Listeria monocytogenes* and *Escherichia coli* O157:H7 on the surface of a meat slicing knife. *Journal of Food Engineering* 100: 446-451.
47. Roberts, P. and Hope, A. 2003. Virus inactivation by high intensity broad spectrum pulsed light. *Journal of Virological Methods* 110: 61-65.
48. Rowan, N. J., MacGregor, S. J., Anderson, J. G., Fouracre, R. A., McIlvaney, L. and Farish, O. 1999. Pulsed-light inactivation of food-related microorganisms. *Applied and Environmental Microbiology* 65: 1312-1315.
49. Setlow, R. B. and Carrier, W. L. 1966. Pyrimidine dimmers in ultraviolet-irradiated DNAs. *Journal of Molecular Biology* 17: 237-254.
50. Sharma, R. R. and Demirci, A. 2003. Inactivation of *Escherichia coli* O157:H7 on inoculated alfalfa seeds with pulsed ultraviolet light and response surface modeling. *Journal of Food Science* 68: 1448-1453.
51. Slieman, T. A. and Nicholson, W. L. 2000. Artificial and solar ultraviolet radiation induces strand breaks and cyclobutane dimers in *Bacillus subtilis* spore DNA. *Applied and Environmental Microbiology* 66: 199-205.
52. Takeshita, K., Shibato, J., Sameshima, T., Fukunaga, S., Isobe, S. and Arihara, K. 2003. Damage of yeast cells induced by pulsed light irradiation. *International Journal of Food Microbiology* 85 : 151-158.
53. Turtoi, M. and Nicolau, A. 2007. Intense light pulse treatment as alternative method for mould spores destruction on paper-polyethylene packaging material. *Journal of Food Engineering* 83: 47-53.
54. Uysal, P. C. and Kirca, T. A. 2011. Effect of Ultraviolet-C light on anthocyanin content and other quality parameters of pomegranate juice. *Journal of Food Composition and Analysis* 24 (6) :790-795.
55. Wekhof, A. 2000. Disinfection with flash lamps. *PDA Journal of Pharmaceutical Science and Technology* 54: 264-276.
57. Wekhof, A., Trompeter, F. J. and Franken, O. 2001. Pulse
58. Ultraviolet disintegration (PUVD): a new sterilisation mechanism for packaging and broad medical hospital applications. The first international conference on ultraviolet technologies. Washington D.C. USA.
59. Woodling, S. E. and Moraru, C. I. 2005. Influence of surface topography on the effectiveness of pulsed light treatment for the inactivation of *Listeria innocua* on stainless-steel surface. *Journal of Food Science* 70: 345-351.
60. Wuytack, E. Y., Phuong, L. D. T., Aertsen, A., Reyns, K. M. F., Marquenie, D., Ketelaere, D. B., Masschalck, B., Van Opstal, I., Diels, A. M. J. and Michiels, C.
62. W. 2003. Comparison of sublethal injury induced in *Salmonella enterica* serovar Typhimurium by heat and by different nonthermal treatments. *Journal of Food Protection* 66: 31-37.
63. Xenon Corp. 2005. AN-104 application note. Achieving faster cure time with pulsed ultraviolet, available online at <http://www.globalspec.com>.
64. Yang, W. W., Chung, S.Y., Ajayi, O., Krishnamurthy, K., Konan, K. and Goodrich-Schneider, R. 2010. Use of pulsed ultraviolet light to reduce allergenic potency of soybean extracts. *International Journal of Food Engineering* 6 (3): 1-12.
65. Yang, W. W., Mwakatage, N. R., Goodrich-Schneider, R., Krishnamurthy, K. and Rababah, T. M. 2011. Mitigation of major peanut allergens by pulsed ultraviolet light. *Food and Bioprocess Technology* 87: 1-11.