



Grid Interconnection Of Renewable Energy Sources At The Distribution Level With Power-Quality Improvement Features

Damodahr Reddy

CMR college of engineering, India

Ch.Shankar Rao

CMR College of engineering, India

K.Pradeep Kumar Reddy

VidyaVikas Institute of engineering, India

Abstract:

Renewable energy resources (RES) are being increasingly connected in distribution systems utilizing power electronic converters. This project presents a novel control strategy for achieving maximum benefits from these grid-interfacing inverters when installed in 3-phase 4-wire distribution systems. The inverter is controlled to perform as a multi-function device by incorporating active power filter functionality.

The inverter can thus be utilized as: 1) power converter to inject power generated from RES to the grid, and 2) shunt APF to compensate current unbalance, load current harmonics, load reactive power demand and load neutral current. All of these functions may be accomplished either individually or simultaneously. With such a control, the combination of grid-interfacing inverter and the 3-phase 4-wire linear/non-linear unbalanced load at point of common coupling appears as balanced linear load to the grid.

This project has presented a novel control of an existing grid interfacing inverter to improve the quality of power at PCC for a 3-phase 4-wire DG system. It has been shown that the grid-interfacing inverter can be effectively utilized for power conditioning without affecting its normal operation of real power transfer.

1.Introduction

Electric utilities and end users of electric power are becoming increasingly concerned about meeting the growing energy demand. Seventy five percent of total global energy demand is supplied by

the burning of fossil fuels. But increasing air pollution, global warming concerns, diminishing fossil fuels and their increasing cost have made it necessary to look towards renewable sources as a future energy solution. Since the past decade, there has been an enormous interest in many countries on renewable energy for power generation. The market liberalization and government's incentives have further accelerated the renewable energy sector growth.

Renewable energy source (RES) integrated at distribution level is termed as distributed generation (DG). The utility is concerned due to the high penetration level of intermittent RES in distribution systems as it may pose a threat to network in terms of stability, voltage regulation and power-quality (PQ) issues. Therefore, the DG systems are required to comply with strict technical and regulatory frameworks to ensure safe, reliable and efficient operation of overall network.

With the advancement in power electronics and digital control technology, the DG systems can now be actively controlled to enhance the system operation with improved PQ at PCC. However, the extensive use of power electronics based equipment and non-linear loads at PCC generate harmonic currents, which may deteriorate the quality of power.

Generally, current controlled voltage source inverters are used to interface the intermittent RES in distributed system. Recently, a few control strategies for grid connected inverters incorporating PQ solution have been proposed. In an inverter operates as active inductor at a certain frequency to absorb the harmonic current. But the exact calculation of network inductance in real-time is difficult and may deteriorate the control performance.

A similar approach in which a shunt active filter acts as active conductance to damp out the harmonics in distribution network is proposed. A control strategy for renewable interfacing inverter based on – theory is proposed. In this strategy both load and inverter current sensing is required to compensate the load current harmonics.

The non-linear load current harmonics may result in voltage harmonics and can create a serious PQ problem in the power system network. Active power filters (APF) are extensively used to compensate the load current harmonics and load unbalance at

distribution level. This results in an additional hardware cost. However, in this paper authors have incorporated the features of APF in the, conventional inverter interfacing renewable with the grid, without any additional hardware cost. Here, the main idea is the maximum utilization of inverter rating which is most of the time underutilized due to intermittent nature of RES.

It is shown in this paper that the grid-interfacing inverter can effectively be utilized to perform following important functions: 1) transfer of active power harvested from the renewable resources (wind, solar, etc.); 2) load reactive power demand support; 3) current harmonics compensation at PCC; and 4) current unbalance and neutral current compensation

n in case of 3-phase 4-wire system. Moreover, with adequate control of grid-interfacing inverter, all the four objectives can be accomplished either individually or simultaneously. The PQ constraints at the PCC can therefore be strictly maintained within the utility standards without additional hardware cost.

2.Modelling Of Case Study

2.1.System Description

The proposed system consists of RES connected to the dc-link of a grid-interfacing inverter as shown in Fig.1 The voltage source inverter is a key element of a DG system as it interfaces the renewable energy source to the grid and delivers the generated power. The RES may be a DC source or an AC source with rectifier coupled to dc-link. Usually, the fuel cell and photovoltaic energy sources generate power at variable low dc voltage, while the variable speed wind turbines generate power at variable ac voltage. Thus, the power generated from these renewable sources needs power conditioning (i.e., dc/dc or ac/dc) before connecting on dc-link. The dc-capacitor decouples the RES from grid and also allows independent control of converters on either side of dc-link.

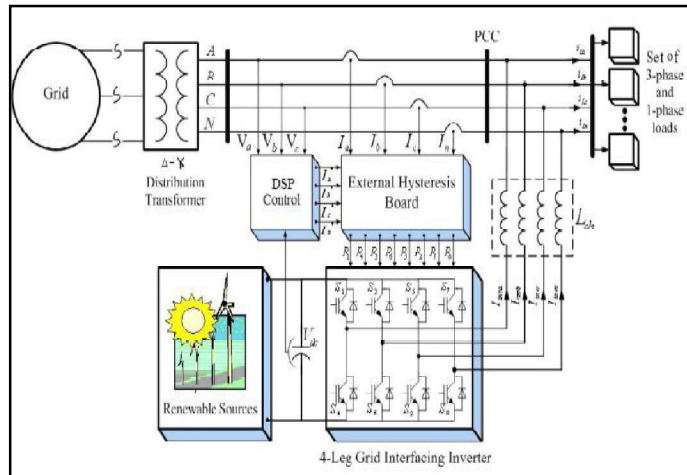

Figure 1: Schematic of proposed renewable based distributed generation system

3.Dc-Link Voltage And Power Control Operation

Due to the intermittent nature of RES, the generated power is of variable nature. The dc-link plays an important role in transferring this variable power from renewable energy source to the grid. RES are represented as current sources connected to the dc-link of a grid-interfacing inverter.

Fig.2 shows the systematic representation of power transfer from the renewable energy resources to the grid via the dc-link. The current injected by renewable into dc-link at voltage level V_{dc} can be given as

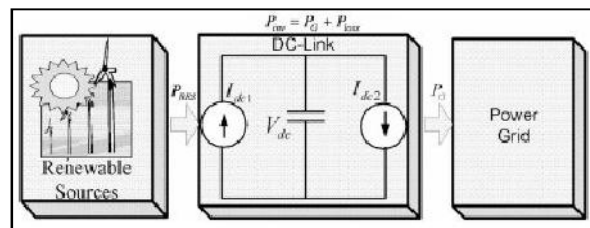

Figure 2: DC-Link equivalent diagram.

$$I_{dc1} = \frac{P_{RES}}{V_{dc}} \dots\dots\dots (1)$$

Where P_{RES} is the power generated from RES.

The current flow on the other side of dc-link can be represented as,

$$I_{dc2} = \frac{P_{inv}}{V_{dc}} = \frac{P_G + P_{Loss}}{V_{dc}} \dots\dots\dots (2)$$

Where P_{INV} , P_G and P_{LOSS} are total power available at grid-interfacing inverter side, active power supplied to the grid and inverter losses, respectively. If inverter losses are negligible then $P_{RES} = P_G$.

3.Control Of Grid Interfacing Inverter

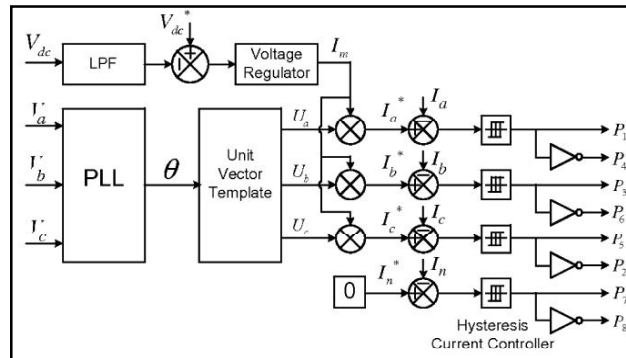

Figure 3: Block diagram representation of grid-interfacing inverter control

The control diagram of grid- interfacing inverter for a 3-phase 4-wire system is shown in Fig. 53 The fourth leg of inverter is used to compensate the neutral current of load. The main aim of proposed approach is to regulate the power at PCC during: 1) $P_{RES} = 0$; 2) $P_{RES} < \text{total load power } (P_L)$; and 3) $P_{RES} > P_L$. While performing the power management operation, the inverter is actively controlled in such a way that it always draws/ supplies fundamental active power from/ to the grid. If the load connected to the PCC is non-linear or unbalanced or the combination of both, the given control approach also compensates the harmonics, unbalance, and neutral current. The duty ratio of inverter switches are varied in a power cycle such that the combination of load and inverter injected power appears as balanced resistive load to the grid. The regulation of dc-link voltage carries the information regarding the exchange of active power in between renewable source and grid. Thus the output of dc-link voltage regulator results in an active current I_m . The multiplication of active current component (I_m) with unity grid voltage vector templates (U_a , U_b and U_c) generates the reference grid currents (I_a^* , I_b^* and I_c^*). The reference grid neutral current (I_n^*) is set to zero, being the instantaneous sum of balanced grid currents. The grid synchronizing angle (θ) obtained from phase locked loop (PLL) is used to generate unity vector template.

$$U_a = \sin(\theta) \dots\dots\dots (3)$$

$$U_b = \sin\left(\theta - \frac{2\pi}{3}\right) \dots\dots\dots (4)$$

$$U_c = \sin\left(\theta + \frac{2\pi}{3}\right) \dots\dots\dots (5)$$

The actual dc-link voltage (V_{dc}) is sensed and passed through a first-order *low pass filter* (LPF) to eliminate the presence of switching ripples on the dc-link voltage and in the generated reference current signals. The difference of this filtered dc-link voltage and reference dc-link voltage (V_{dc}^*) is given to a discrete- PI regulator to maintain a constant dc-link voltage under varying generation and load conditions. The dc-link voltage error ($V_{dcerr}(n)$) at n^{th} sampling instant is given as:

$$V_{dcerr}(n) = V_{dc}^*(n) - V_{dc}(n) \dots\dots\dots (6)$$

The output of discrete-PI regulator at n^{th} sampling instant is expressed as

$$I_m(n) = I_m(n-1) + K_{PV_{dc}}(V_{dcerr}(n) - V_{dcerr}(n-1)) + K_{IV_{dc}}V_{dcerr}(n) \dots\dots\dots (7)$$

Where $K_{PV_{dc}} = 10$ and $K_{IV_{dc}} = 0.05$ are proportional and integral gains of dc-voltage regulator. The instantaneous values of reference three phase grid currents are computed as

$$I_a^* = I_m \cdot U_a \dots\dots\dots (8)$$

$$I_b^* = I_m \cdot U_b \dots\dots\dots (9)$$

$$I_c^* = I_m \cdot U_c \dots\dots\dots (10)$$

The neutral current, present if any, due to the loads connected to the neutral conductor should be compensated by forth leg of grid-interfacing inverter and thus should not be drawn from the grid. In other words, the reference current for the grid neutral current is considered as zero and can be expressed as

$$I_n^* = 0 \dots\dots\dots (11)$$

The reference grid currents (I_a^* , I_b^* , I_c^* and I_n^*) are compared with actual grid currents (I_a , I_b , I_c and I_n) to compute the current errors as

$$I_{aerr} = I_a^* - I_a \dots\dots\dots (12)$$

$$I_{berr} = I_b^* - I_b \dots\dots\dots (13)$$

$$I_{cerr} = I_c^* - I_c \dots\dots\dots (14)$$

$$I_{\text{err}} = I_n^* - I_n, \dots \dots \dots (15)$$

These current errors are given to hysteresis current controller. The hysteresis controller then generates the switching pulses (P_1 to P_g) for the gate drives of grid-interfacing inverter. The average model of 4-leg inverter can be obtained by the following state space equations

$$\frac{dI_{\text{Inva}}}{dt} = \frac{(V_{\text{Inva}} - V_a)}{L_{\text{sh}}} \dots \dots \dots (16)$$

$$\frac{dI_{\text{Invb}}}{dt} = \frac{(V_{\text{Invb}} - V_b)}{L_{\text{sh}}} \dots \dots \dots (17)$$

$$\frac{dI_{\text{Invc}}}{dt} = \frac{(V_{\text{Invc}} - V_c)}{L_{\text{sh}}} \dots \dots \dots (18)$$

$$\frac{dI_{\text{Invn}}}{dt} = \frac{(V_{\text{Invn}} - V_n)}{L_{\text{sh}}} \dots \dots \dots (19)$$

$$\frac{dV_{\text{dc}}}{dt} = \frac{(I_{\text{Invad}} + I_{\text{Invbd}} + I_{\text{Invcd}} + I_{\text{Invnd}})}{C_{\text{dc}}} \dots \dots \dots (20)$$

Where V_{Inva} , V_{Invb} , V_{Invc} , and V_{Invn} are the three-phase ac switching voltages generated on the output terminal of inverter. These inverter output voltages can be modeled in terms of instantaneous dc bus voltage and switching pulses of the inverter as

$$V_{\text{Inva}} = \frac{(P_1 - P_4)}{2} V_{\text{dc}} \dots \dots \dots (21)$$

$$V_{\text{Invb}} = \frac{(P_3 - P_6)}{2} V_{\text{dc}} \dots \dots \dots (22)$$

$$V_{\text{Invc}} = \frac{(P_5 - P_2)}{2} V_{\text{dc}} \dots \dots \dots (23)$$

$$V_{\text{Invn}} = \frac{(P_7 - P_8)}{2} V_{\text{dc}} \dots \dots \dots (24)$$

Similarly the charging currents I_{Invad} , I_{Invbd} , I_{Invcd} , and I_{Invnd} on dc bus due to the each leg of inverter can be expressed as

$$I_{\text{Invad}} = I_{\text{Inva}}(P_1 - P_4) \dots \dots \dots (25)$$

$$I_{\text{Invbd}} = I_{\text{Invb}}(P_3 - P_6) \dots \dots \dots (26)$$

$$I_{\text{Invcd}} = I_{\text{Invc}}(P_5 - P_2) \dots \dots \dots (27)$$

$$I_{\text{Invnd}} = I_{\text{Invn}}(P_7 - P_8) \dots \dots \dots (28)$$

The switching pattern of each IGBT inside inverter can be formulated On the basis of error between actual and reference current of inverter, which can be explained as:

If $I_{Inva} < (I_{Inva}^* - h_b)$, then upper switch S_1 will be OFF ($P_1 = 0$) and lower switch will be ON ($P_1 = 1$) in the phase “a” leg of inverter. If $I_{Inva} > (I_{Inva}^* + h_b)$, then upper switch will be ON ($P_1 = 1$) and lower switch S_4 will be OFF ($P_1 = 0$) in the phase “a” leg of inverter.

Where h_b is the width of hysteresis band. On the same principle, the switching pulses for the other remaining three legs can be derived.

4. Matlab Designs Of Case Study And Results

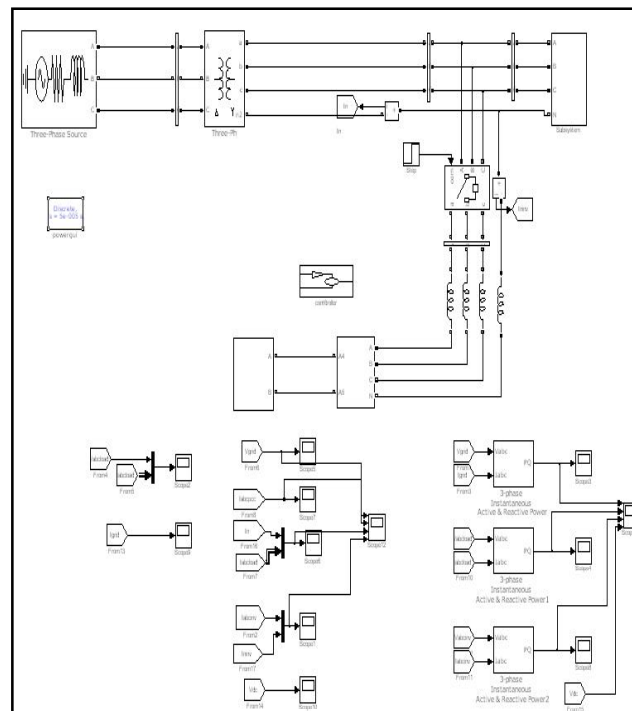

Figure 4: mat lab simulation design

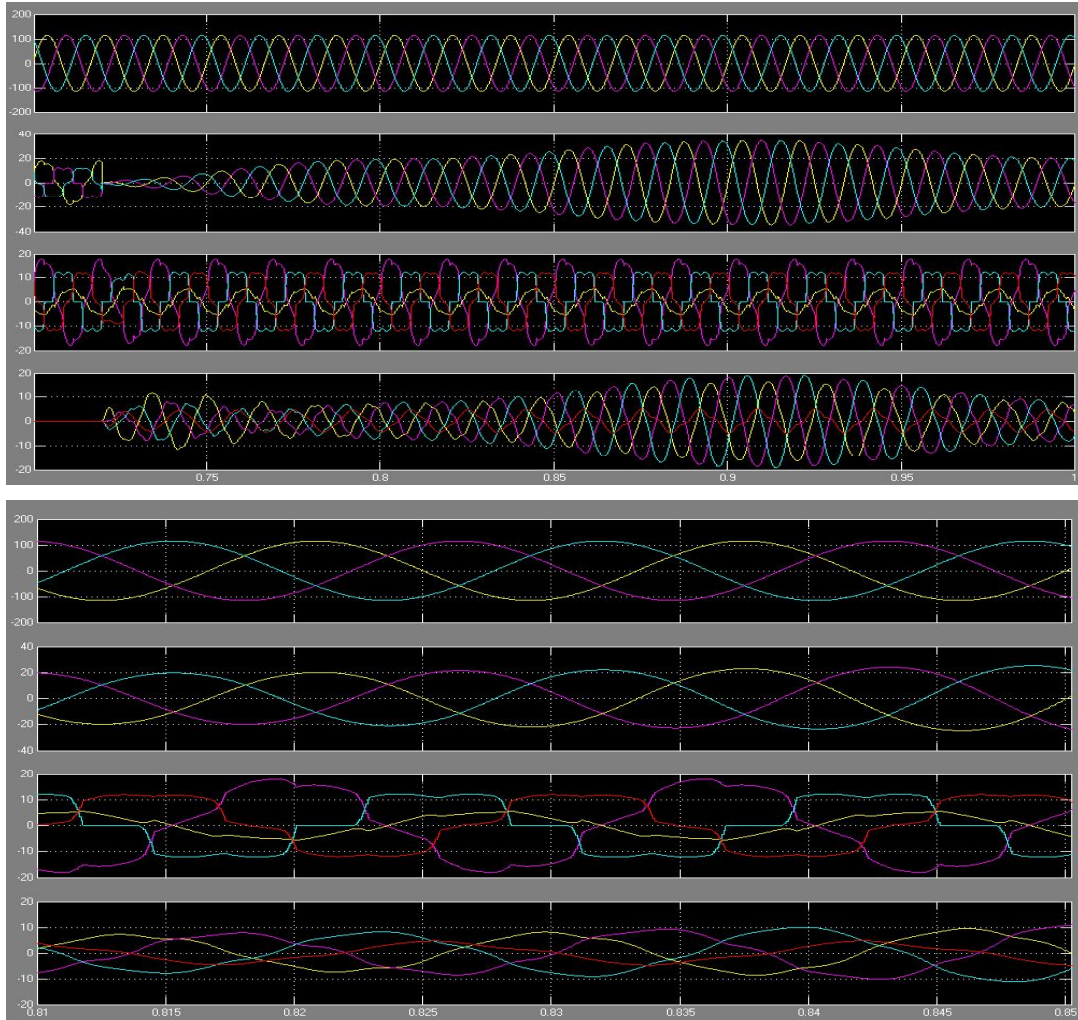

Figure 5: Simulation results: (a) Grid voltages, (b) Grid Currents (c) Unbalanced load currents, (d) Inverter Currents

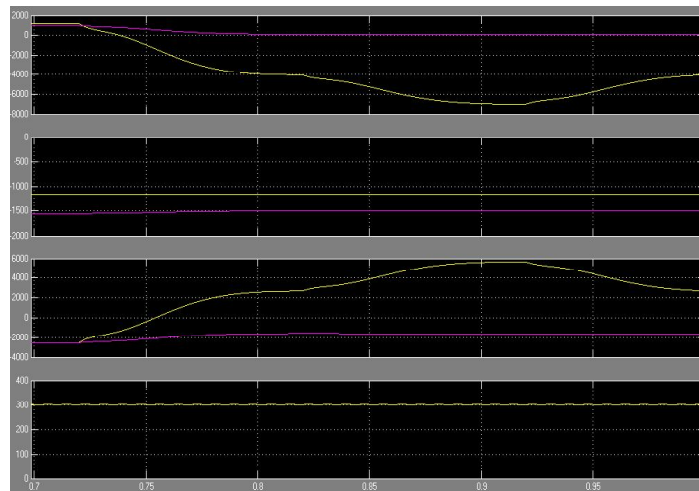

Figure 6: Simulation results: (a) PQ-Grid, (b) PQ-Load, (c) PQ-Inverter, (d) dc-link voltage.

5. Conclusion

This paper has presented a novel control of an existing grid interfacing inverter to improve the quality of power at PCC for a 3-phase 4-wire DG system. It has been shown that the grid-interfacing inverter can be effectively utilized for power conditioning without affecting its normal operation of real power transfer. The grid-interfacing inverter with the proposed approach can be utilized to: i) Inject real power generated from RES to the grid, and/or, ii) Operate as a shunt Active Power Filter (APF). This approach thus eliminates the need for additional power conditioning equipment to improve the quality of power at PCC. Extensive MATLAB/Simulink simulation as well as the DSP based experimental results have validated the proposed approach and have shown that the grid-interfacing inverter can be utilized as a multi-function device.

It is further demonstrated that the PQ enhancement can be achieved under three different scenarios: 1) $P_{RES}=0$, 2) $P_{RES} < P_{Load}$, and 3) $P_{RES} > P_{Load}$. The current unbalance, current harmonics and load reactive power, due to unbalanced and non-linear load connected to the PCC, are compensated effectively such that the grid side currents are always maintained as balanced and sinusoidal at unity power factor. Moreover, the load neutral current is prevented from flowing into the grid side by compensating it locally from the fourth leg of inverter. When the power generated from RES is more than the total load power demand, the grid-interfacing inverter with the proposed control approach not only fulfills the total load active and reactive power demand) but also delivers the excess generated sinusoidal active power to the grid at unity power factor.

6.Reference

1. J. M. Guerrero, L. G. de Vicuna, J. Matas, M. Castilla, and J. Miret, "A wireless controller to enhance dynamic performance of parallel inverters in distributed generation systems," *IEEE Trans. Power Electron.*, vol. 19, no. 5, pp. 1205–1213, Sep. 2004.
2. J. H. R. Enslin and P. J. M. Heskes, "Harmonic interaction between a large number of distributed power inverters and the distribution network," *IEEE Trans. Power Electron.*, vol. 19, no. 6, pp. 1586–1593, Nov. 2004.
3. U. Borup, F. Blaabjerg, and P. N. Enjeti, "Sharing of nonlinear load in parallel-connected three-phase converters," *IEEE Trans. Ind. Appl.*, vol. 37, no. 6, pp. 1817–1823, Nov./Dec. 2001.
4. P. Jintakosonwit, H. Fujita, H. Akagi, and S. Ogasawara, "Implementation and performance of cooperative control of shunt active filters for harmonic damping throughout a power distribution system," *IEEE Trans. Ind. Appl.*, vol. 39, no. 2, pp. 556–564, Mar./Apr. 2003.
5. J. P. Pinto, R. Pregitzer, L. F. C. Monteiro, and J. L. Afonso, "3-phase 4-wire shunt active power filter with renewable energy interface," presented at the Conf. IEEE Renewable Energy & Power Quality, Seville, Spain, 2007.
6. F. Blaabjerg, R. Teodorescu, M. Liserre, and A. V. Timbus, "Overview of control and grid synchronization for distributed power generation systems," *IEEE Trans. Ind. Electron.*, vol. 53, no. 5, pp. 1398–1409, Oct. 2006.
7. J. M. Carrasco, L. G. Franquelo, J. T. Bialasiewicz, E. Galván, R. C. P. Guisado, M. Á. M. Prats, J. I. León, and N. M. Alfonso, "Power electronic systems for the grid integration of renewable energy sources: A survey," *IEEE Trans. Ind. Electron.*, vol. 53, no. 4, pp. 1002–1016, Aug. 2006.
8. B. Renders, K. De Gussemé, W. R. Ryckaert, K. Stockman, L. Vandeveldé, and M. H. J. Bollen, "Distributed generation for mitigating voltage dips in low-voltage distribution grids," *IEEE Trans. Power. Del.*, vol. 23, no. 3, pp. 1581–1588, Jul. 2008.
9. V. Khadkikar, A. Chandra, A. O. Barry, and T. D. Nguyen, "Application of UPQC to protect a sensitive load on a polluted distribution network," in *Proc. Annu. Conf. IEEE Power Eng. Soc. Gen. Meeting*, 2006, pp. 867–872.
10. M. Singh and A. Chandra, "Power maximization and voltage sag/swell ride-through capability of PMSG based variable speed wind energy conversion system," in *Proc. IEEE 34th Annu. Conf. Indus. Electron. Soc.*, 2008, pp. 2206–2211.