



## **Dynamic Performance Of STATCOM Under Various Faults In Power System**

**R. K. Sampath**

M-Tech Scholar, Power Electronics, Department Of Electrical And Electronics Engineering, Pvp Siddhartha College Of Engineering, Vijayawada (A.P), India

**C. Kumar**

Associate Professor, Department Of Electrical And Electronics Engineering, Pvp Siddhartha College Of Engineering, Vijayawada (A.P), India.

### **Abstract:**

*The STATCOM (Synchronous Static Compensator) based on voltage source converter (VSC) is used for voltage regulation in transmission and distribution system. The STATCOM can rapidly supply dynamic VARs required during system faults for voltage support. Strict requirements of STATCOM losses and total system loss penalty preclude the use of PWM (Pulse-Width Modulation) for VSC based STATCOM applications. This constraint of implementing VSC without PWM functionality, results in over-currents and trips of the STATCOM during and after system faults, when its VAR support functionality is most required. In this paper, we propose and develop an “emergency PWM” strategy to prevent over-currents (and trips) in the VSC during and after single line to ground system faults, LLLG faults and to ensure that the STATCOM supplies required reactive power. Due to nonlinear load harmonics will be introduced into the system. System performance during a nonlinear load connected without any fault is also considered. The Simulation results are shown for a 48-pulse VSC based  $\pm 100$  MVAR STATCOM connected to a 2-bus power strategy to prevent VSC over-currents and to supply required reactive power under line to ground system faults.*

**Key words:** TATCOM, Voltage Source Converter (VSC), Pulse-width Modulation (PWM), Single line to ground fault.

## 1.Introduction

Flexible AC Transmission systems(FACTS) controllers are emerging as an effective and promising alternative to enhance the power transfer capability and stability of the network by redistributing the line flow and regulating the bus voltages. Static VAR compensator (SVC) and Thyristor controlled series compensator (TCSC) are some of the commonly used FACTS controllers , The developments in the field of power electronics, particularly Gate Turn-off (GTO) based devices, have introduced a new family of versatile FACTS controllers, namely static synchronous compensator (STATCOM) ,The STATCOM is one of the custom power devices that received much attention for improving system stability, with the development of power electronics technology, custom power devices play important role in bringing unprecedented efficiency improvement and cost effectiveness in modern electrical power system [1,2]. The custom power is relatively new concept aimed at achieving high power quality, operational flexibility and controllability of electrical power systems [3-5]. The possibility of generating or absorbing controllable reactive power with various power electronic switching converters has long been recognized [6-8]. The STATCOM based on voltage source converter (VSC) is used for voltage regulation in transmission and distribution systems[8-12]. The STATCOM can rapidly supply dynamic VAR's during system faults for voltage support. In this paper, we propose and develop an "emergency PWM" strategy to prevent over-currents (and trips) in the VSC during line to ground faults, all though PWM technique results in higher switching losses but it recompense total system loss. This limitation of implementing VSC with PWM functionality, results in avoiding over-currents and trips of the STATCOM supplies required reactive power. With "emergency PWM" strategy STATCOM gains capability to prevent over-currents and trips in the VSC based STATCOM. Simulation results are presented for a 48-pulse VSC based  $\pm 100$  MVAR STATCOM connected to a 2-bus power system. The operating characteristic of compensator during steady state, capacitive and inductive modes validate "emergency PWM" strategy [13] to prevent VSC over-currents and to supply required reactive power under line to ground system faults[9-12].

## 2.VSC'S BASIC STRUCTURE

Fig. 1 shows the 48-pulse voltage source converter topology for STATCOM application. The VSC consists of four (Inv 1 - Inv4) 3-level Neutral Point Clamped (NPC) converters which are connected in series by four (T1-T4) transformer coupling. The primary side of

the transformer is connected in series as shown in Fig. 1. Due to the strict loss outlay for STATCOM application, each VSC is operated at fundamental frequency switching or in square-wave mode. The gating of VSCs is Phase-shifted so as to yield 48 pulse output voltage waveform with series transformer coupling on the primary side. The performance of the STATCOM under system faults (such as single line-ground faults) results in converter over currents and STATCOM trips.

Fig. 2 shows the phase B bus voltage dips for 4 cycles due to line-ground fault in the system. It has been noticed that primary STATCOM currents are large during system faults and results in ST ATCOM tripping. Examining further, it is seen that the VSCs "stop gating" during the fault due to over current strategy and enable the STATCOM to remain online, but cannot prevent the ST ATCOM trip recovering from the fault. It is realized that the VAR support functionality of the ST ATCOM is required the most during and after a system fault. This problem is the motivation for this work.

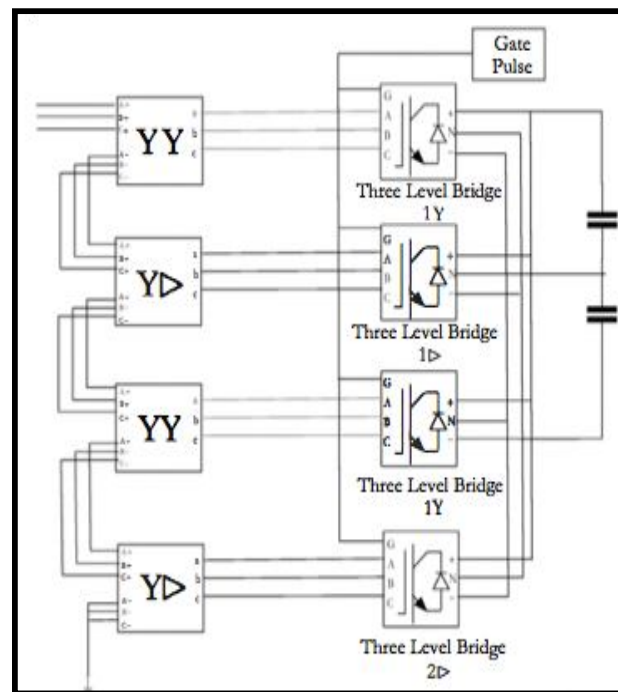
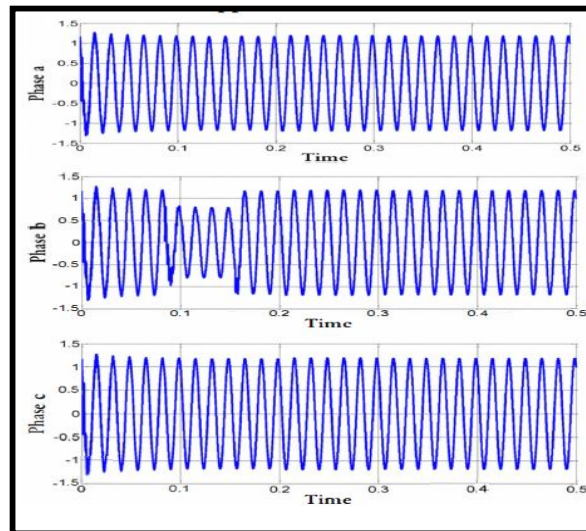

Figure 1: The 48 –Pulse Voltage Source Converter Circuit For  $\pm 100$  MVA STATCOM Application



*Figure2: Performances Under Remote Single Line To Ground Fault Resulting In Phase B Bus Voltage Sag*

Fig.4 shows the 2-bus 500 kV power system simulation model with 48 pulses implemented VSC based  $\pm 100$  MVAR STATCOM. Fig.4 shows the implemented angle controlled ( $\alpha$ ) STATCOM controller. An inner feedback loop is used to regulate the STATCOM instantaneous reactive power current  $I_q$  shunt, reminding that this control is achieved only by controlling  $\alpha$ , of the inverter output voltage relative towards the transmission line voltage, this technique makes it possible to maintain a constant maximum ratio between the inverter Output voltage and the VSC dc-capacitor. The reference value for the reactive current control loop is generated by an outer loop responsible for the system voltage control ( $V_{bus\_ref}$ ). This outer control loop is similar to that used in conformist static VAR compensators, and includes an adjustable slope/droop setting that defines the voltage error at full STATCON reactive output. There is an unavoidable delay in the feedback of the voltage regulating loop because of the time taken to compute the positive sequence fundamental bus voltage ( $V_{bus}$ ). as a result an extremely fast response (typically 1/4 cycle) can be achieved for the reactive current controller ( $I_q$  Shunt), the response time of the voltage regulator is typically about half Cycle of the line voltage.

### **3.Control Strategy**

The proposed solution is based on "emergency PWM" mode, where the VSCs will individually detect and self implement PWM switching to control their phase (VSC pole and device) currents within predetermined limits. Each VSC will ensure that its over-current limit is not reached during and after a system fault, and under any bus voltage

condition (including negative sequence and harmonics). This control strategy enables the STATCOM to remain online and recovering from a system fault, when its VAR support is required the most. Fig.6 and Fig.7 shows the VSC phase voltages and currents under normal and faulted conditions with "emergency pwm". The phase current rapidly increases at the onset of the fault and is typically higher than the over-current limit of the VSC devices. This "emergency PWM" concept is illustrated in such a way that the VSC phase voltage is modulated to control the phase (VSC pole and device) current during the fault. It is seen that the VSC phase current is controlled such that the STATCOM still delivers required reactive power (or current) during the fault. The extra switching's in the VSC will result in higher losses during this period. However, the priority is to keep the STATCOM online to support the bus voltage during and recovering from system faults.

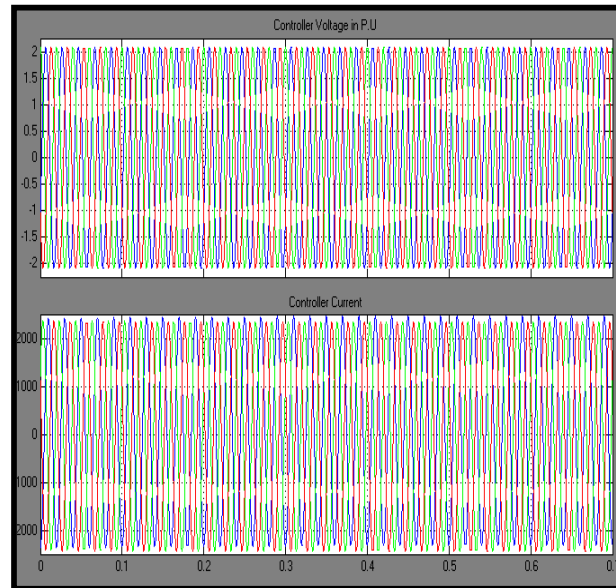

*Figure3 :VSC Phase Voltage And Current Under Normal Condition*

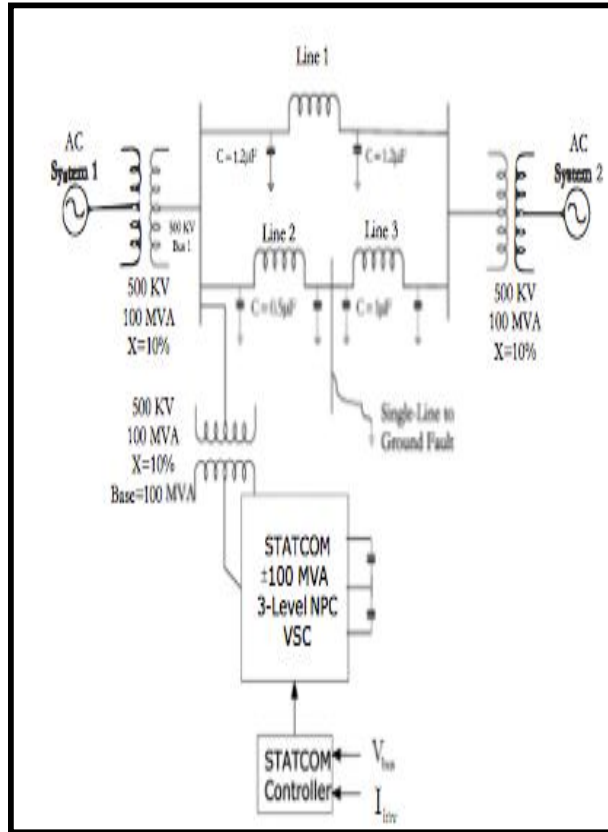

Figure 4 :Shows The 2-Bus 500 Kv Power System Simulation Model With 48 Pulses Implemented VSC Based ±100 MV AR STATCOM

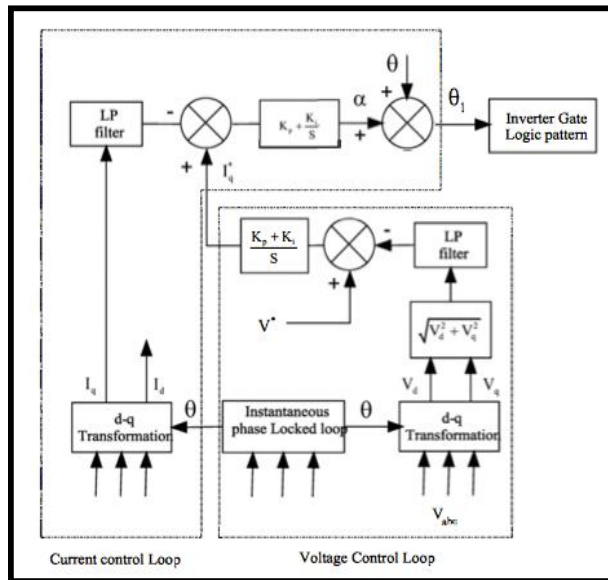

Figure 5: STATCOM Control Block Diagram

#### 4.Control Method Instantaneous Power Theory

The proposed instantaneous real-power ( $p$ ) theory derives from the conventional  $p$ - $q$  theory or instantaneous power theory concept and uses simple algebraic calculations. It operates in steady-state or transient as well as for generic voltage and current power systems that allowing to control the active power filters in real-time. The active filter should supply the oscillating portion of the instantaneous active current of the load and hence makes source current sinusoidal.

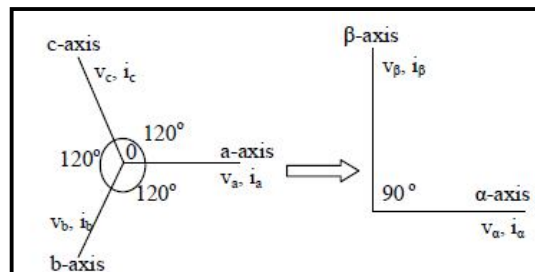

Figure 6: A-B Coordinates Transformation

The  $p$ - $q$  theory performs a Clarke transformation of a stationary system of coordinates  $a$   $b$   $c$  to an orthogonal reference system of coordinates  $\alpha$   $\beta$ . In  $a$   $b$   $c$  coordinates axes are fixed on the same plane, apart from each other by  $120^\circ$  that as shown in Fig 6. The instantaneous space vectors voltage and current  $V_a$ ,  $i_a$  are set on the  $a$ -axis,  $V_b$ ,  $i_b$  are on the  $b$  axis, and  $V_c$ ,  $i_c$  are on the  $c$  axis. These space vectors are easily transformed into  $\alpha$   $\beta$  coordinates. The instantaneous source voltages  $v_{sa}$ ,  $v_{sb}$ ,  $v_{sc}$  are transformed into the  $\alpha$   $\beta$  coordinate's voltage  $v_\alpha$ ,  $v_\beta$  by Clarke transformation as follows:

$$\begin{pmatrix} v_\alpha \\ v_\beta \end{pmatrix} = \sqrt{\frac{2}{3}} \begin{pmatrix} 1 & -\frac{1}{2} & -\frac{1}{2} \\ 0 & \frac{\sqrt{3}}{2} & -\frac{\sqrt{3}}{2} \end{pmatrix} \begin{pmatrix} v_{sa} \\ v_{sb} \\ v_{sc} \end{pmatrix} \quad (1)$$

Similarly, the instantaneous source current  $i_{sa}$ ,  $i_{sb}$ ,  $i_{sc}$  also transformed into the  $\alpha$   $\beta$  coordinate's current  $i_\alpha$ ,  $i_\beta$  by Clarke transformation that is given as;

$$\begin{pmatrix} i_\alpha \\ i_\beta \end{pmatrix} = \sqrt{\frac{2}{3}} \begin{pmatrix} 1 & -\frac{1}{2} & -\frac{1}{2} \\ 0 & \frac{\sqrt{3}}{2} & -\frac{\sqrt{3}}{2} \end{pmatrix} \begin{pmatrix} i_{sa} \\ i_{sb} \\ i_{sc} \end{pmatrix} \quad (2)$$

Where  $\alpha$  and  $\beta$  axes are the orthogonal coordinates. They  $V_\alpha$ ,  $i_\alpha$  are on the  $\alpha$ -axis, and  $V_\beta$ ,  $i_\beta$  are on the  $\beta$ -axis.



#### 4.1. Real-Power ( $p$ ) calculation

The orthogonal coordinates of voltage and current  $v_\alpha, i_\alpha$  are on the  $\alpha$ -axis and  $v_\beta, i_\beta$  are on the  $\beta$ -axis. Let the instantaneous real-power calculated from the  $\alpha$ -axis and  $\beta$ -axis of the current and voltage respectively. These are given by the conventional definition of real-power as :

$$P_{ac} = v_\alpha i_\alpha + v_\beta i_\beta \quad (3)$$

This instantaneous real-power  $p_{ac}$  is passed to first order Butterworth design based 50 Hz low pass filter (LPF) for eliminating the higher order components; it allows the fundamental component only. These LPF indicates ac components of the real-power losses and it's denoted as  $p_{ac}$

The DC power loss is calculated from the comparison of the dc-bus capacitor voltage of the cascaded inverter and desired reference voltage. The proportional and integral gains (PI Controller) are determining the dynamic response and settling time of the dc-bus capacitor voltage. The DC component power losses can be written as

$$P_{DC(loss)} = [v_{DC,ref} - v_{DC}] \left[ k_P + \frac{k_I}{s} \right] \quad (4)$$

The instantaneous real-power ( $p$ ) is calculated from the AC component of the real-power loss  $p_{ac}$  and the DC power loss  $p_{DC(Loss)}$ ; it can be defined as follows;

$$p = \overline{p_{ac}} + P_{DC(Loss)} \quad (5)$$

The instantaneous current on the  $\alpha\beta$  coordinates of  $i_{c\alpha}$  and  $i_{c\beta}$  are divided into two kinds of instantaneous current components; first is real-power losses and second is reactive power losses, but this proposed controller computes only the real-power losses. So the  $\alpha, \beta$  coordinate currents  $i_{c\alpha}, i_{c\beta}$  are calculated from the  $v_\alpha, v_\beta$  voltages with instantaneous real power  $p$  only and the reactive power  $q$  is assumed to be zero. This approach reduces the calculations and shows better performance than the conventional methods. The  $\alpha, \beta$  coordinate currents can be calculated as

$$\begin{pmatrix} i_{c\alpha} \\ i_{c\beta} \end{pmatrix} = \frac{1}{v_\alpha^2 + v_\beta^2} \begin{pmatrix} v_\alpha & v_\beta \\ v_\beta & -v_\alpha \end{pmatrix} \begin{pmatrix} p \\ 0 \end{pmatrix} \quad (6)$$

From this equation, we can calculate the orthogonal coordinate's active-power current. The  $\alpha$ -axis of the instantaneous active current is written as:



$$i_{\alpha p} = \frac{v_{\alpha} P}{v_{\alpha}^2 + v_{\beta}^2} \quad (7)$$

Similarly, the  $\beta$  - axis of the instantaneous active current is written as:

$$i_{\beta p} = \frac{v_{\beta} P}{v_{\alpha}^2 + v_{\beta}^2} \quad (8)$$

Let the instantaneous powers  $p(t)$  in the  $\alpha$  -axis and the  $\beta$  - axis is represented as  $p_{\alpha}$  and  $p_{\beta}$  respectively. They are given by the definition of real-power as follows:

$$p(t) = v_{\alpha}(t) i_{\alpha p}(t) + v_{\beta}(t) i_{\beta p}(t) \quad (9)$$

From this equation (10), substitute the orthogonal coordinates  $\alpha$  -axis active power (8) and  $\beta$  -axis active power (8); we can calculate the real-power  $p(t)$  as follows

$$p(t) = v_{\alpha}(t) \left( \frac{v_{\alpha} P}{v_{\alpha}^2 + v_{\beta}^2} \right) + v_{\beta}(t) \left( \frac{v_{\beta} P}{v_{\alpha}^2 + v_{\beta}^2} \right) \quad (10)$$

The AC and DC component of the instantaneous power  $p(t)$  is related to the harmonics currents. The instantaneous real power generates the reference currents required to compensate the distorted line current harmonics and reactive power.

## 5. Simulation Under Line To Ground And Lll-G Faults

The system simulation diagram is shown in Figure 4 with a 2-bus 500 kV power system. The  $\pm 100$  MV AR STATCOM is implemented with a 48-pulse VSC and is connected to a 500 kV bus as shown in Figure 3. A general fault generator is implemented at bus 2, which results in a voltage dip at the STATCOM bus. Attention is focused on single line-ground faults and STATCOM performance with the proposed "emergency PWM" concept in this section. Results given in per unit values, with 1.0 P.U as 500 kV. During steady state operation VSC voltage is in phase with system voltage. If the voltage generated by the VSC is higher (or lower) than the system voltage, then STATCOM generates(or absorbs) reactive power. The amount of reactive power depends on the VSC voltage magnitude and on the transformer leakage reactances. The fundamental component of VSC voltage is controlled by varying dc bus voltage. In order to vary dc voltage and therefore the reactive power, the VSC voltages angle(alpha) which is normally kept at close to zero is now phase shifted. This VSC voltage may lag or lead

and produces a temporary flow of active power which results in increase or decrease of dc capacitor voltages. With help of emergency pwm the output voltage distortion and capacitor ripple current can be reduced to any desired degree. Thus static VAR generator, employing a perfect voltage sourced converter, would produce sinusoidal output voltages, would draw sinusoidal reactive current from ac system

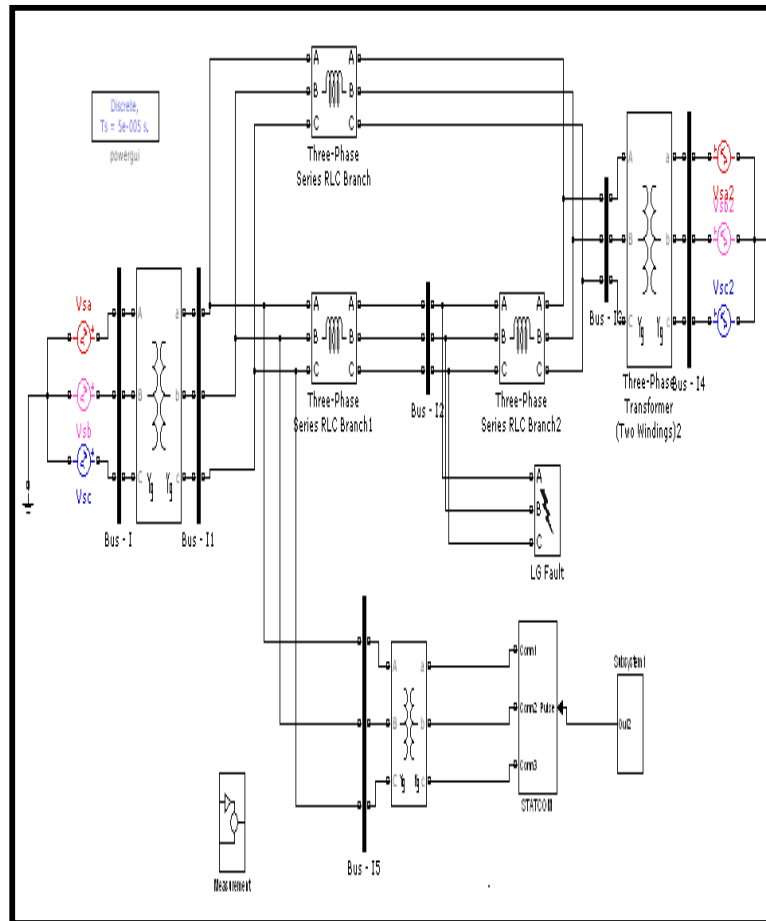
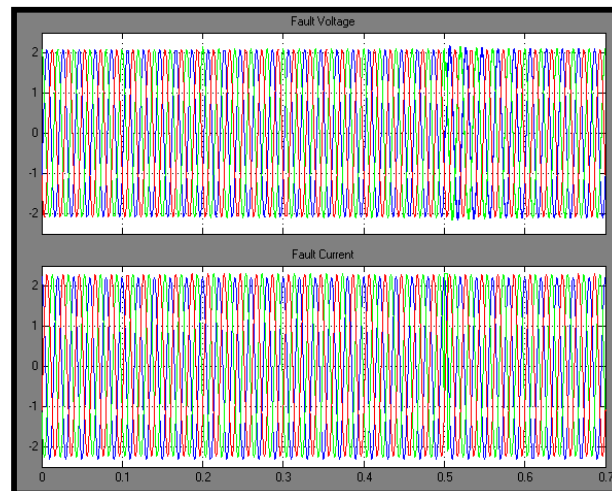
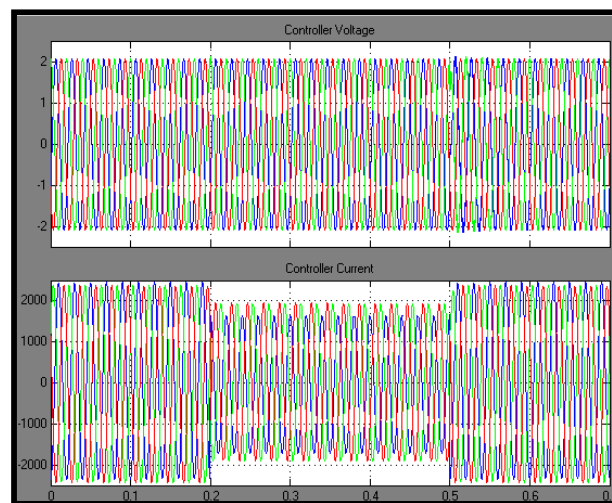

Figure7: Simulink Circuit Of Statcom Connected System



*Figure 8 :VSC Voltage And Current Waveforms Under Normal Condition*

Figure.11 shows dc link voltage variations under normal operating conditions, in fact any change in dc link voltage represents variation in load.



*Figure9 : VSC Voltage And Current Under LG Fault*

Fig.9 shows STATCOM operation in voltage regulation mode with emergency PWM under fault conditions. During fault conditions the inverter currents are very high this is the main reason for tripping and by implementing VSC with PWM functionality, avoids over-current and trips and in Fig. 9 (a) It is clearly shown that bus voltage, injected currents are optimum, this ensures that STATCOM is in online and function without tripping, and from Fig. 9( c), we can examine continuous disparity in dc link voltage at 0.1 sec, during this period VAR output of STATCOM can change extremely rapidly, but the voltage controller takes time to determine the desired output, based on line voltage measurement. Once controller measures the desired voltage then STATCOM starts supplying reactive power to the load.

Fig. 9 (b) shows reactive power supplied by the STATCOM under critical conditions. it is varying from inductive to capacitive within 0.2 to 0.3sec which shows STATCOM supplying adequate reactive power under fault condition. Fig.9 shows the STATCOM controller voltages and currents which are in permissible limits under fault conditions.

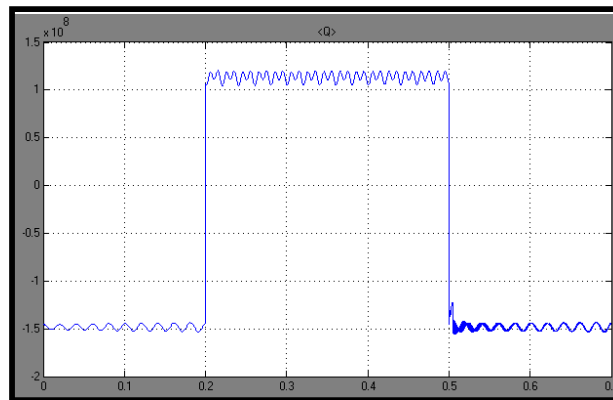

Figure10: STATCOM Reactive Power  $Q$  In MVAR

STATCOM operates in two modes either capacitive or inductive mode, these are known according to Var variations. And dc link voltage always resembles STATCOM response, it is constant under normal stipulation. When ac voltage reduces STATCOM reacts fastly and supplies necessary reactive power. At this condition reactive power  $Q$  is positive which resembles it is in capacitive mode, whereas operation is vice versa when ac voltage increases.

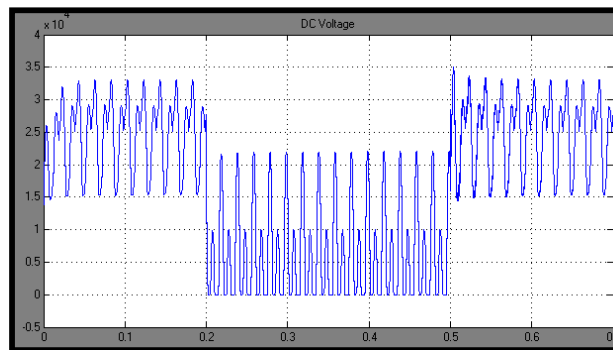

Figure11: DC Link-Voltage

### 6.LLL-G Fault

Fig.12 shows dynamic response of STATCOM under LLL-G faults, as these faults are sever, at this condition the inverters currents are very high than rated, but still STATCOM continuous to be in online without tripping and after a particular interval of time system comes to steady state. This is verified through Fig 12(a). The moment fault

occurred, bus voltages starts to fall but STATCOM responds abruptly and commence within minimum interval of time and starts supplying reactive power, these can be seen in Fig 13. From Fig.14, we can examine dc link voltage variations, under fault conditions and once STATCOM starts supplying then it gradually settles down i.e at point 0.2 sec, this signify

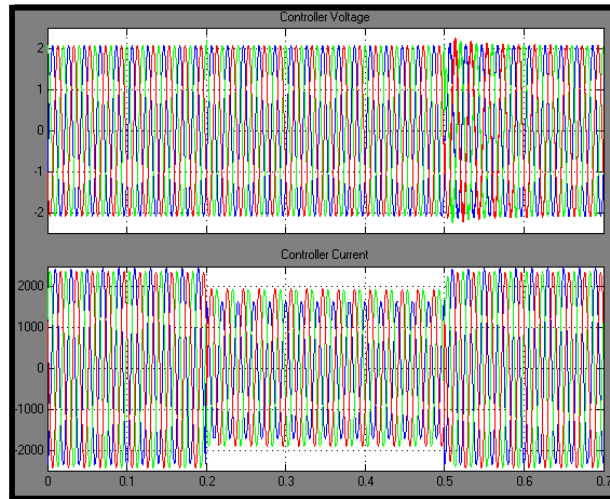

Figure 12 :VSC Voltage And Current Under LLL Fault

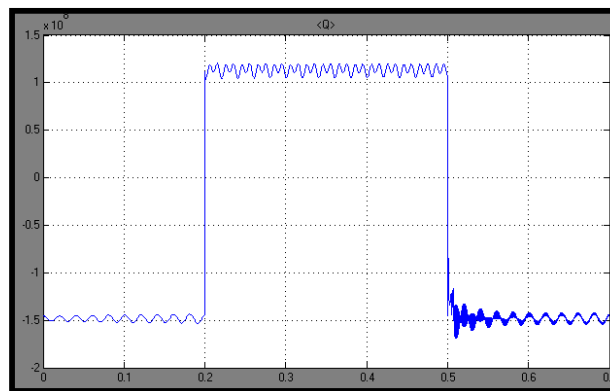

Figure13 :STATCOM Reactive Power Q In MVAR



Figure14 : DC Link-Voltage

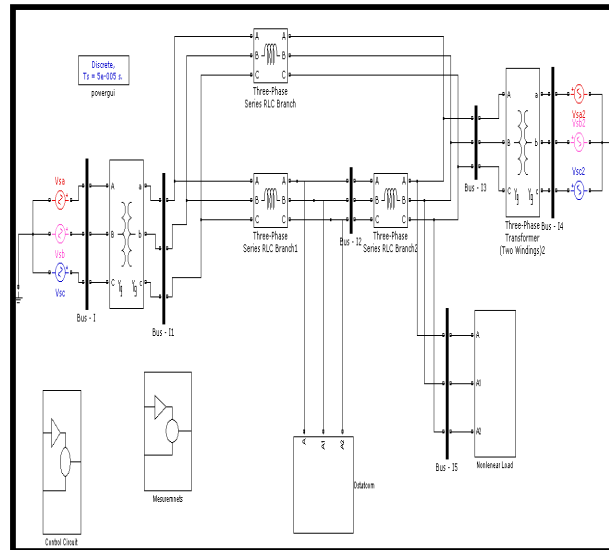

Figure15: Simulation Circuit Of STATCOM Connected To Nonlinear Load

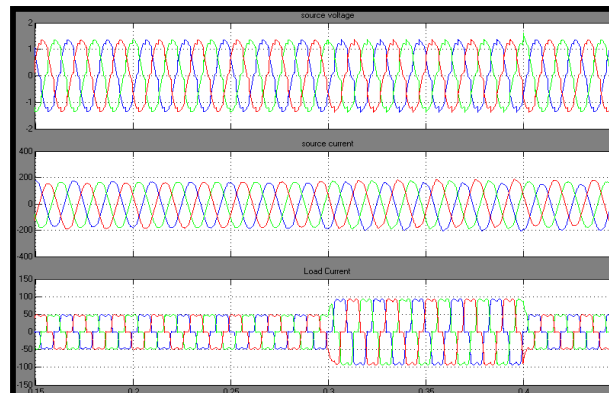

Figure16: Source Voltage, Current And Load Current Waveforms

Fig.15 shows the simulation circuit of the STATCOM connected to nonlinear load and Fig.16 shows the source voltage, current and the load current.

## 7.Conclusion

This paper describes dynamic performance of STATCOM when it is subjected to L-G and LLL-G faults. The operating characteristic of compensator during steady state, capacitive and inductive modes of operation has been reasonably acceptable and competitive for design of an economical dynamic static compensator and by implementing "emergency PWM" strategy STATCOM gains capability to prevent over-currents and trips in the VSC based STATCOM. Simulation results are presented for a 48-pulse VSC based  $\pm 100$  MV AR ST ATCOM connected to a 2-bus power system. Bus

voltages, and primary injected currents of STATCOM, under normal and faulted conditions shown in detail. In addition to this a nonlinear load is connected and operated at no fault conditions, and harmonics are eliminated in the source current. This enables online operation of the STATCOM and supplies required reactive power when it is most required. Thus the performance of STATCOM has improved with the new control strategy



**8.Reference**

1. N.G. Hingorani, "Power Electronics in Electric Utilities: Role Of Power Electronics In Future Power Systems," Proceedings of the IEEE, vol. 76, pp. 481, 1988.
2. N.G. Hingorani and L.Gyugyi, "Understanding FACTS: concepts And Technology of Flexible AC Transmission Systems: IEEE press, 2000.
3. L.Gyugyi, "Reactive Power Generation And Control By Thyristor Circuits," IEEE Trans. Ind. Appl., vol. Ia-15, no. 5, pp. 521-532, Sept.ioct., 1979
4. L.Gyugyi, "Dynamic Compensation of Ac Transmission Lines by Solid-State Synchronous Voltage Sources," IEEE, PES Summer Power Meeting, Paper No. 93 SM 434-1 PWRD, 1993.
5. C.W. Edwards et al., "Advanced Static Var Generator Employing GTO Thyristors," IEEE, PES winter Power Meeting, Paper No. 38wml09-1, 1988.
6. L.Gyugyi, "Dynamic Compensation of Ac Transmission Lines by Solid-State Synchronous Voltage Sources," IEEE, PES Summer Power Meeting, Paper No. 93 sm 434-1 pwrD, 1993
7. C.Schauder et al. "TVA STATCON project: design, installation and Commissioning," CIGRE paper 14-106, 1996.
8. E.Larsen et al. "Benefits of GTO-Based Compensation Systems for Electric Utility Applications," IEEE, PES summer power meeting, Paper no. 91 sm 397-0 TWRD, 1991.
9. J.B.Ekanayake and M.Jenkins, "A Three-Level Advanced Static Var Compensator," Power Delivery, IEEE Transactions on, vol. 11, pp. 540, 1996.
10. "Evaluation of Advanced Static Var Generators," EPRI Report No. EI- 3397 MAY 1984.
11. C. Schauder et al., "Development of A  $\pm 100$  Mvar Static Condenser For Voltage Control Of Transmission Systems," IEEE, PES Summer Power Meeting, Paper No. 94 sm 479-6 pwrD, 1994.
12. N.G. Hingorani et al. "Static Condenser – Prototype Application," CIGRE Paper, New Zealand, 1993.
13. S.Bhattachalya, Z. Xi, " A Practical Operation Strategy for STATCOM Under Single Line To Ground Faults In Power System" ,IEEE PSCE conf.,Nov.2006,Atlanta.