



Pavement Deterioration And Its Causes

Sharad S.Adlinge

Student Of M.E (Civil), J.J. Magdum College of Engg., Kolhapur, India

A.K.Gupta

Assistant Professor, J.J. Magdum College of Engg., Kolhapur, India

Abstract:

In this paper Pavement failure is defined in terms of decreasing serviceability caused by the development of cracks and ruts. Before going into the maintenance strategies, we must look into the causes of failure of bituminous pavements. Failures of bituminous pavements are caused due to many reasons or combination of reasons. Application of correction in the existing surface will enhance the life of maintenance works as well as that of strengthening layer. It has been seen that only 3 parameters i.e. unevenness index, pavement cracking and rutting are considered while other distresses have been omitted while going for maintenance operations. Along with the maintenance techniques there are various methods for pavement preservation which will help in enhancing the life of pavement and delaying of its failure. The purpose of this study was to evaluate the possible causes of pavement distresses, and to recommend remedies to minimize distress of the pavement. The paper describes lessons learnt from pavement failures and problems experienced during the last few years on a number of projects in India. Based on the past experiences various pavement preservation techniques and measures are also discussed which will be helpful in increasing the serviceable life of pavement.

Key words: Pavement, unevenness index, rutting, distresses.

1.Introduction

1.1.Meaning Of Pavement

That with which anything is paved; a floor or covering of solid material, laid so as to make a hard and convenient surface for travel; a paved road or sidewalk; a decorative interior floor of tiles colored bricks.

1.2.Types Of Pavement

Pavements are typically divided into the following three general categories: flexible, rigid and unpaved (gravel or dirt).

1.2.1.Flexible (Bituminous Pavements)

Flexible pavements are constructed of several layers of natural granular material covered with one or more

waterproof bituminous surface layers, and as the name imply, is considered to be flexible. A flexible pavement will flex (bend) under the load of a tyre. The objective with the design of a flexible pavement is to avoid the excessive flexing of any layer, failure to achieve this will result in the over stressing of a layer, which ultimately will cause the pavement to fail. In flexible pavements, the load distribution pattern changes from one layer to another, because the strength of each layer is different. The strongest material (least flexible) is in the top layer and the weakest material (most flexible) is in the lowest layer. The reason for this is that at the surface the wheel load is applied to a small area, the result is high stress levels, deeper down in the pavement, the wheel load is applied to larger area, the result is lower stress levels thus enabling the use of weaker materials

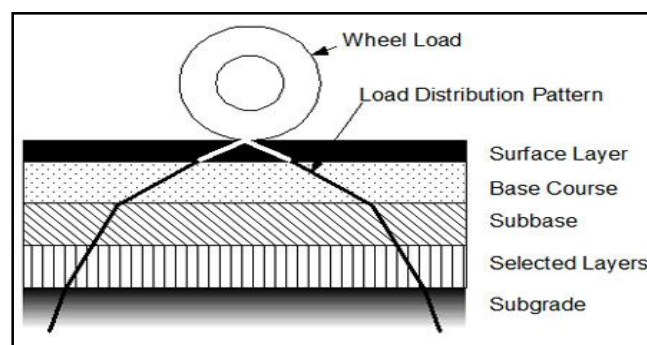

Figure 1: Load distribution of flexible pavement

1.2.2.Rigid (Concrete) Pavements

Rigid pavements are composed of a PCC surface course. Such pavements are substantially "stiffer" than flexible pavements due to the high modulus of elasticity of the PCC material. Further, these pavements can have reinforcing steel, which is generally used to reduce or eliminate joints. The increased rigidity of concrete allows the concrete surface layer to bridge small weak areas in the supporting layer through what is known as beam action. This allows the placement of rigid pavements on relatively weak supporting layers, as long as the supporting layer material particles will not be carried away by water forced up by the pumping action of wheel loads.

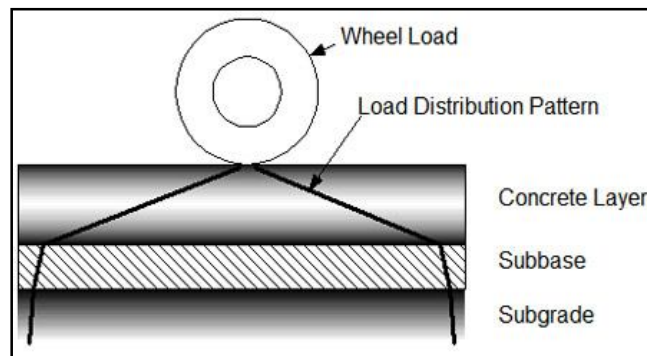

Figure 2: Load distribution of rigid pavement

1.3.Pavement Functions

The primary functions of a pavement are to:

1.3.1.Provide A Reasonably Smooth Riding Surface

A smooth riding surface (Low Roughness) is essential for riding comfort, and over the years it has become the measure of how road users perceive a road. Roughness can arise from a number of causes, most often however it is from pavement distress due to structural deformation.

1.3.2.Provide Adequate Surface Friction (Skid Resistance)

In addition to a riding comfort, the other road user requirement is that of safety. Safety, especially during wet conditions can be linked to a loss of surface friction between the

tyre and the pavement surface. A pavement must therefore provide sufficient surface friction and texture to ensure road user safety under all conditions.

1.3.3. Protect The Subgrade

The supporting soil beneath the pavement is commonly referred to as the subgrade, should it be over-stressed by the applied axle loads it will deform and lose its ability to properly support these axle loads. Therefore, the pavement must have sufficient structural capacity (strength and thickness) to adequately reduce the actual stresses so that they do not exceed the strength of the subgrade. The strength and thickness requirements of a pavement can vary greatly depending on the combination of subgrade type and loading condition (magnitude and number of axle loads).

1.3.4. Provide Waterproofing

The pavement surfacing acts as a waterproofing surface that prevent the underlaying support layers including the subgrade from becoming saturated through moisture ingress. When saturated, soil loses its ability to adequately support the applied axle loads, which will lead to premature failure of the pavement.

2. Factors Influencing The Performance Of A Pavement

2.1. Traffic

Traffic is the most important factor influencing pavement performance. The performance of pavements is mostly influenced by the loading magnitude, configuration and the number of load repetitions by heavy vehicles. The damage caused per pass to a pavement by an axle is defined relative to the damage per pass of a standard axle load, which is defined as a 80 kN single axle load (E80). Thus a pavement is designed to withstand a certain number of standard axle load repetitions (E80's) that will result in a certain terminal condition of deterioration.

2.2. Moisture (Water)

Moisture can significantly weaken the support strength of natural gravel materials, especially the subgrade. Moisture can enter the pavement structure through cracks and holes in the surface, laterally through the subgrade, and from the underlying water table through capillary action. The result of moisture ingress is the lubrication of particles, loss of particle interlock and subsequent particle displacement resulting in pavement failure.

2.3. Subgrade

The subgrade is the underlying soil that supports the applied wheel loads. If the subgrade is too weak to support the wheel loads, the pavement will flex excessively which ultimately causes the pavement to fail. If natural variations in the composition of the subgrade are not adequately addressed by the pavement design, significant differences in pavement performance will be experienced.

2.4. Construction Quality

Failure to obtain proper compaction, improper moisture conditions during construction, quality of materials, and accurate layer thickness (after compaction) all directly affect the performance of a pavement. These conditions stress the need for skilled staff, and the importance of good inspection and quality control procedures during construction.

2.5. Maintenance

Pavement performance depends on what, when, and how maintenance is performed. No matter how well the pavement is built, it will deteriorate over time based upon the mentioned factors. The timing of maintenance is very important, if a pavement is permitted to deteriorate to a very poor condition, as illustrated by point B in Error! Reference source not found., then the added life compared with point A, is typically about 2 to 3 years. This added life would present about 10 percent of the total life. The cost however of repairing the road at point B is minimum four times the cost if the road had been repaired at point A. The postponement of maintenance hold further implications, in that for the cost of repairing one badly deteriorated road (Point B), four roads at point A would have to be deferred, which would mean that in a few years the

rehabilitation cost could be 16 times as much. Thus, postponing maintenance because of budget constraints, will result in a significant financial penalty within a few years.

3.Pavement Deterioration And Its Types

Pavement deterioration is the process by which distress (defects) develop in the pavement under the combined effects of traffic loading and environmental conditions.

3.1.Types Of Pavement Deterioration

The four major categories of common asphalt pavement surface distresses are:

- Cracking
- Surface deformation
- Disintegration (potholes, etc.)
- Surface defects (bleeding, etc.)

3.1.1.Cracking

The most common types of cracking are:

- Fatigue cracking
- Longitudinal cracking
- Transverse cracking
- Block cracking
- Slippage cracking
- Reflective cracking
- Edge cracking

2.Fatigue Cracking (Alligator Cracking)

Fatigue cracking is commonly called alligator cracking. This is a series of interconnected cracks creating small, irregular shaped pieces of pavement. It is caused by failure of the surface layer or base due to repeated traffic loading (fatigue). Eventually the cracks lead to disintegration of the surface, as shown in Figure. The final result is potholes. Alligator cracking is usually associated with base or drainage problems. Small areas may be fixed with a patch or area repair. Larger areas require reclamation or reconstruction. Drainage must be carefully examined in all cases.



Figure 3: High severity alligator cracking

3. Longitudinal cracki

Longitudinal cracks are long cracks that run parallel to the center line of the roadway. These may be caused by frost heaving or joint failures, or they may be load induced. Understanding the cause is critical to selecting the proper repair. Multiple parallel cracks may eventually form from the initial crack. This phenomenon, known as deterioration, is usually a sign that crack repairs are not the proper solution.



Figure 4: Longitudinal Cracking

3. Transverse cracking

Transverse cracks form at approximately right angles to the centerline of the roadway. They are regularly spaced and have some of the same causes as longitudinal cracks. Transverse cracks will initially be widely spaced (over 20 feet apart). They usually begin as hairline or very narrow cracks and widen with age. If not properly sealed and maintained, secondary or multiple cracks develop, parallel to the initial crack. The reasons for transverse cracking, and the repairs, are similar to those for longitudinal cracking. In addition, thermal issues can lead to low-temperature cracking if the asphalt cement is too hard. Figure shows a low-severity transverse crack.



Figure 5: Low severity transverse crack

4. Block cracking

Block cracking is an interconnected series of cracks that divides the pavement into irregular pieces. This is sometimes the result of transverse and longitudinal cracks intersecting. They can also be due to lack of compaction during construction. Low severity block cracking may be repaired by a thin wearing course. As the cracking gets more severe, overlays and recycling may be needed. If base problems are found, reclamation or reconstruction may be needed. Figure shows medium to high severity block cracking.

5. Slippage cracking

Slippage cracks are half-moon shaped cracks with both ends pointed towards the oncoming vehicles. They are created by the horizontal forces from traffic. They are usually a result of poor bonding between the asphalt surface layer and the layer below. The lack of a tack coat is a prime factor in many cases. Repair requires removal of the slipped area and repaving. Be sure to use a tack coat in the new pavement.

6. Reflective cracking

Reflective cracking occurs when a pavement is overlaid with hot mix asphalt concrete and cracks reflect up through the new surface. It is called reflective cracking because it reflects the crack pattern of the pavement structure below. As expected from the name, reflective cracks are actually covered over cracks reappearing in the surface. They can be repaired in similar techniques to the other cracking noted above. Before placing any overlays or wearing courses, cracks should be properly repaired.

7. Edge Cracking

Edge cracks typically start as crescent shapes at the edge of the pavement. They will expand from the edge until they begin to resemble alligator cracking. This type of cracking results from lack of support of the shoulder due to weak material or excess moisture. They may occur in a curbed section when subsurface water causes a weakness in the pavement. At low severity the cracks may be filled. As the severity increases, patches and replacement of distressed areas may be needed. In all cases, excess moisture should be eliminated, and the shoulders rebuilt with good materials. Figure shows high severity edge cracking.

7.1. Surface Deformation

Pavement deformation is the result of weakness in one or more layers of the pavement that has experienced movement after construction. The deformation may be accompanied by cracking. Surface distortions can be a traffic hazard.

The basic types of surface deformation are:

- Rutting
- Corrugations
- Shoving
- Depressions
- Swell

7.1.1. Rutting

Rutting is the displacement of pavement material that creates channels in the wheel path. Very severe rutting will actually hold water in the rut. Rutting is usually a failure in one or more layers in the pavement. The width of the rut is a sign of which layer has failed. A very narrow rut is usually a surface failure, while a wide one is indicative of a subgrade failure. Inadequate compaction can lead to rutting. Figure shows an example of rutting due to subgrade

Failure. Minor surface rutting can be filled with micropaving or paver-placed surface treatments. Deeper ruts may be shimmed with a truing and leveling course, with an overlay placed over the shim. If the surface asphalt is unstable, recycling of the surface may be the best option. If the problem is in the subgrade layer, reclamation or reconstruction may be needed.

7.1.2. Corrugation

Corrugation is referred to as washboarding because the pavement surface has become distorted like a washboard. The instability of the asphalt concrete surface course may be caused by too much asphalt cement, too much fine aggregate, or rounded or smooth textured coarse aggregate. Corrugations usually occur at places where vehicles accelerate or decelerate. Minor corrugations can be repaired with an overlay or surface milling. Severe corrugations require a deeper milling before resurfacing.

7.1.3. Shoving

Shoving is also a form of plastic movement in the asphalt concrete surface layer that creates a localized bulging of the pavement. Locations and causes of shoving are similar to those for corrugations. Figure shows an example of shoving. Repair minor shoving by removing and replacing. For large areas, milling the surface may be required, followed by an overlay.

7.1.4. Depressions

Depressions are small, localized bowl-shaped areas that may include cracking. Depressions cause roughness, are a hazard to motorists, and allow water to collect. Depressions are typically caused by localized consolidation or movement of the supporting layers beneath the surface course due to instability. Repair by excavating and rebuilding the localized depressions. Reconstruction is required for extensive depressions.

7.1.5. Swell

A swell is a localized upward bulge on the pavement surface. Swells are caused by an expansion of the supporting layers beneath the surface course or the subgrade. The expansion is typically caused by frost heaving or by moisture. Subgrades with highly plastic clays can swell in a manner similar to frost heaves (but usually in warmer months). Repair swells by excavating the inferior subgrade material and rebuilding the removed area. Reconstruction may be required for extensive swelling.

7.2. *Disintegration*

The progressive breaking up of the pavement into small, loose pieces is called disintegration. If

the disintegration is not repaired in its early stages, complete reconstruction of the pavement may be needed.

The two most common types of disintegration are:

1. Potholes
2. Patches

7.2.1. Potholes

Potholes are bowl-shaped holes similar to depressions. They are a progressive failure. First, small fragments of the top layer are dislodged. Over time, the distress will progress downward into the lower layers of the pavement. Potholes are often located in areas of poor drainage, as seen in Figure. Potholes are formed when the pavement disintegrates under traffic loading, due to inadequate strength in one or more layers of the pavement, usually accompanied by the presence of water. Most potholes would not occur if the root cause was repaired before development of the pothole. Repair by excavating and rebuilding. Area repairs or reconstruction may be required for extensive potholes.



Figure 10: Potholes caused by poor drainage

7.2.2. Patches

A patch is defined as a portion of the pavement that has been removed and replaced. Patches are usually used to repair defects in a pavement or to cover a utility trench. Patch failure can lead to a more widespread failure of the surrounding pavement. Some people do not consider patches as a pavement defect. While this should be true for high quality patches as is done in a semipermanent patch, the throw and roll patch is just a cover. The underlying cause is still under the pothole. To repair a patch, a semi-permanent patch should be placed. Extensive potholes may lead to area repairs or reclamation. Reconstruction is only needed if base problems are the root source of the potholes.

7.3.Surface Defects

Surface defects are related to problems in the surface layer. The most common types of surface distress are:

- Ravelling
- Bleeding
- Polishing
- Delamination

7.3.1.Ravelling

Ravelling is the loss of material from the pavement surface. It is a result of insufficient adhesion between the asphalt cement and the aggregate. Initially, fine aggregate breaks loose and leaves small, rough patches in the surface of the pavement. As the disintegration continues, larger aggregate breaks loose, leaving rougher surfaces. Ravelling can be accelerated by traffic and freezing weather. Some ravelling in chip seals is due to improper construction technique. This can also lead to bleeding. Repair the problem with a wearing course or an overlay.



Figure 12: High severity ravelling of asphalt surface

7.3.2.Bleeding

Bleeding is defined as the presence of excess asphalt on the road surface which creates patches of asphalt cement. Excessive asphalt cement reduces the skid-resistance of a pavement, and it can become very slippery when wet, creating a safety hazard. This is caused by an excessively high asphalt cement content in the mix, using an asphalt cement with too low a viscosity (too flowable), too heavy a prime or tack coat, or an improperly applied seal coat. Bleeding occurs more often in hot weather when the

asphalt cement is less viscous (more flowable) and the traffic forces the asphalt to the surface. Figure 13 shows an example of bleeding during hot weather.

7.3.3. Polishing

Polishing is the wearing of aggregate on the pavement surface due to traffic. It can result in a dangerous low friction surface. A thin wearing course will repair the surface.

4. Causes Of Pavement Deterioration

- Sudden increase in traffic loading especially on new roads where the design is based on lesser traffic is a major cause of cracking. After construction of good road, traffic of other roads also shifts to that road. This accelerates the fatigue failure (Alligator Cracking).
- Temperature variation ranging from 50° C to below zero conditions in the plain areas of North and Central India leads to bleeding and cracking.
- Provision of poor shoulders leads to edge failures.
- Provision of poor clayey subgrade results in corrugation at the surface and increase in unevenness.
- Poor drainage conditions especially during rainy seasons, force the water to enter the pavement from the sides as well as from the top surface. In case of open graded bituminous layer, this phenomenon becomes more dangerous and the top layer gets detached from the lower layers.
- If the temperature of bitumen/bituminous mixes is not maintained properly, then it also leads to pavement failure. Over heating of bitumen reduces the binding property of bitumen. If the temperature of bituminous mix has been lowered down then the compaction will not be proper leading to longitudinal corrugations.

5.Reference

1. Ankit Gupta (2004). Report on Case Studies on Failure of Bituminous Pavements Report Submitted to PWD, Aligarh. 2004. pp-1-14.
2. David P. Orr (2006) Pavement Maintenance Engineer Cornell Local Roads Program. Cornell Local Roads Program. pp-17-40.
3. Iliya Yut, Case Study on Perpetual Flexible Pavement in Connecticut, Compendium of Papers from the First International Conference on Pavement Preservation.(paper 104).pp-1 14.
4. K Sitaramanjanyulu, P.K. Kanchan, B.M. Sharma, M N Nagabhushana 1998 .INDIAN TOOLS FOR ASSESSMENT OF MAINTENANCE NEEDS. 4th International Conference on Managing Pavements (1998)pp-1-11.
5. Norman R, (2009) Extending Pavement Life by Forestalling Crack Reflection, Compendium of Papers from the First International Conference on Pavement Preservation. pp -2-8.
6. Praveen Kumar (2004), Case Studies on Failure of Bituminous Pavements. Paper from first international conference on pavement preservation(paper 52). pp-1-5.