

THE INTERNATIONAL JOURNAL OF BUSINESS & MANAGEMENT

Employee Engagement: Developing a Conceptual Framework

Dr. Sarit Prava Das

Professor, Institute for Technology and Management, India

Parna Mishra

Assistant Professor, Institute for Technology and Management, India

Abstract:

Employee engagement is the state in which employees feel passionate about their jobs, are committed to the organization, and put discretionary effort into their work. The challenge today is not just in terms of how to correctly measure employee engagement, but also to be able to sustain the same. This is where creating the correct engagement framework is fundamental to the business strategy. This study has been undertaken to develop a conceptual framework of employee engagement which help the organisations to engage the diverse workforce.

1. Introduction

The buzz word of the current globalised economy is employee engagement and this term is still debated and researched both by academia and corporate houses. Employee engagement is a workplace approach designed to ensure that employees are committed to their organisation's goals and values, motivated to contribute to organisational success, and are able at the same time to enhance their own sense of well-being. In addition, the employee mix of today's generation which constitutes both Gen X and Gen Y are looking for environment where they can be engaged and feel that they are contributing in a positive way to something larger than themselves. In particular, engagement is a two-way approach organisations must work to engage the employee, who in turn has a choice about the level of engagement to offer the employer. Each reinforces the other. An engaged employee experiences a blend of job satisfaction, organisational commitment, job involvement and feelings of empowerment. Despite there being some debate about the precise meaning of employee engagement there are three things which we have attempted to identify in this paper. The first one being what are the key factors or drivers which effects engagement, whether it can be correlated with job satisfaction, organisation commitment and employee turnover. Most importantly employers can do a great deal to impact on people's level of engagement. That is what makes it so important, as a tool for business success.

1.1. Objective of the study

- Reviewing various employee engagement models.
- Developing a conceptual framework of employee engagement which can be used in the contemporary organisations.

2. Literature Review

2.1. Models of employee engagement

2.1.1. Saks Model

Saks (2006) also had conducted a study with an objective to test a model of the antecedents and consequences of job and organization engagements based on social exchange theory. Saks in his study argues that although both Kahn's (1990) and Maslach et al.'s (2001) models indicate the psychological conditions or antecedents that are necessary for creating an environment of engagement, are not fully able to explain why individuals will respond to these conditions with varying degrees of engagement. A stronger theoretical rationale for explaining employee engagement can be found in social exchange theory (SET). This was the model developed by Saks.

- **Work engagement or Job engagement measures** three dimensions: vigor, dedication, and absorption. The instrument is the Utrecht Work Engagement Scale (UWES) measures work engagement where Vigor is described as, "being fully charged with energy and resilient in one's work even during a regular 'dull' day when nothing particular happens." Dedication is, "being proud of one's work and convinced that what one performs is significant." Finally, absorption is the concept of, "being carried away by work, forgetting everything in one's surroundings, looking at your watch and finding that you have missed your coffee break without even noticing." (Hallberg, 2005).
- **Organization engagement** implies loyalty to organisation which is one of the subcomponents of Organisation Citizenship Behavior (OCB). OCB has several sub-components that can be grouped into seven common dimensions:

helping behavior, sportsmanship, organizational loyalty, organizational compliance, individual initiative, civic virtue, and self-development.

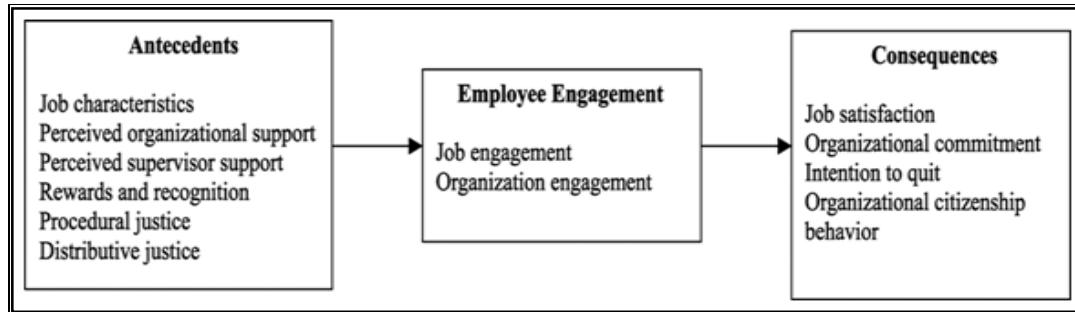

Figure 1: Saks 2006

The results of the study stated that job and organization engagements are related but distinct constructs. Participants' scores were significantly higher for job engagement compared to organization engagement. This study also reflected, the relationships between job and organization engagement with the antecedents and consequences differed in a number of ways suggesting that the psychological conditions that lead to job and organization engagements are different.

2.2. Model of Ologbo C. Andrew and Saudah Sofian

In another study (Ologbo C. Andrew and Saudah Sofian, 2011) employee engagement was addressed incorporating the two types of employee engagement, Job Engagement, which is the level of employee's committed and dedication to his job role and Organization Engagement, which is the level of employee commitment and loyalty to their organization.

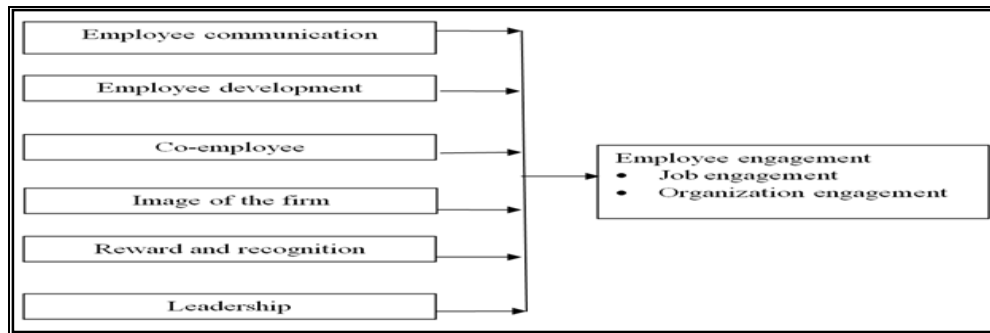

Figure 2: (Ologbo C. Andrew and Saudah Sofian, 2011)

The above diagram demonstrates that employee communication, employee development, Co-employee relationship, image of the firm, reward and recognition and leadership are the determinants of employee engagement.

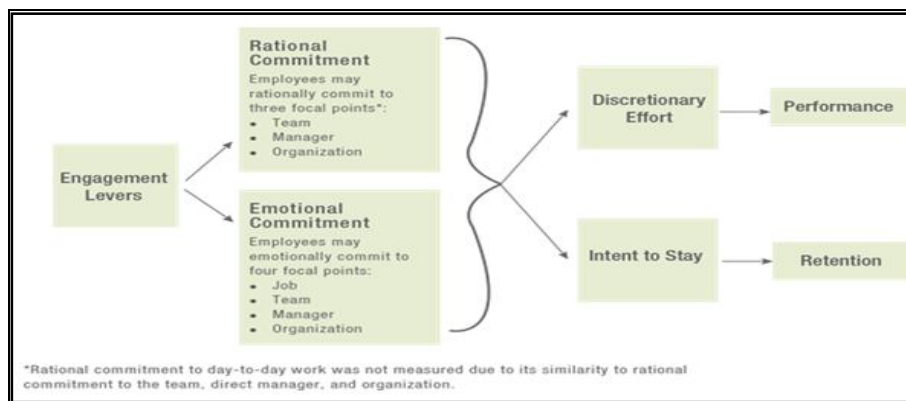

Figure 3: Corporate Council Leadership Model

The above figure depicts that engagement levers to rational commitment. The rational aspect of commitment comprises of salary, monetary benefits, and job growth potential and development. The emotional aspect is based on employees' ethics, beliefs, and satisfaction in regard to his/her job choice. When emotional and rational commitment is achieved then it leads to Discretionary Effort. Discretionary effort implies an employee's willingness to go "above and beyond" the call of duty, such as helping others

with extra work loads volunteering for additional duties, and looking innovative ways to perform their jobs more effectively. Intent to Stay is the desire to stay in the organization, based on whether they intend to look for a new job. (Corporate Leadership Council)

2.3. Job Characteristic model and Employee Engagement

Hackman and Oldham (1980), who developed the Job Characteristics Model. This identifies five core job features:

- **Skill variety:** the extent to which a jobholder is required to use a range of different skills. Identity: the extent to which a job involves the completion of a 'whole' piece of work with end-to-end responsibility.
- **Significance:** the amount of impact that a job has, and the contribution that the job makes.
- **Autonomy:** the amount of discretion that the jobholder has in making decisions about what to do and how to do it.
- **Feedback:** direct information about the performance requirements of the job.

Various studies have reflected the fact that the design of work affects how engaged people are (Humphrey et al., 2007). Christian et al (2011) found that job characteristics such as task variety, autonomy, significance and feedback had all been positively related to engagement. The same relationship have been found in other studies to be linked with motivation (Fried and Ferris, 1987; Hackman and Oldham, 1980). William Kahn's (1990) study of work engagement showed how the context within which work is carried out combines with features of the work itself to foster high levels of engagement. Job design is important for engagement because well designed. When people find their work monotonous and undemanding, this can lead to psychological distress and disengagement as employees interest starts declining (Morgeson and Humphrey, 2006; Work Foundation, 2009).

2.4. Aon Hewitt model of Employee Engagement

Aon Hewitt Engagement, Gallup, Hay Group and Mercer consulting measures engagement across the organisation with the help of the following drivers are illustrated in the diagram that follows.

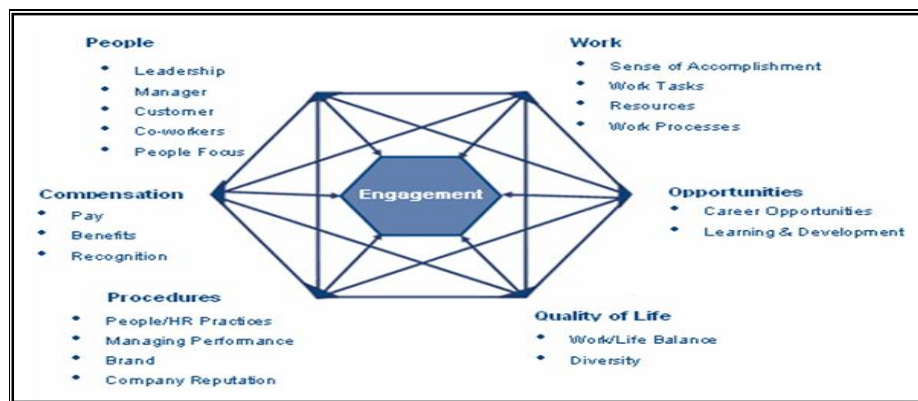

Figure 4

2.5. Sirotta's Three-Factor Model of Engagement

Intellectually Engaged employees are constantly improving the company with new and creative ideas and innovations while maintaining a generally positive view of both the company itself, and their relationship with it.

- **Emotionally Engaged** employees are proud, passionate and enthusiastic about the company.
- **Behaviorally Engaged** employees are willing to go above and beyond for the company, their customers, and their team members while advocating on behalf of company and remaining loyal.

Research suggests that engagement is achieved through the satisfaction of three primary engagement factors.

- **Achievement** – To take pride in one's accomplishments by doing things that matter and doing them well, to receive recognition for one's accomplishments, and to take pride in the organization's accomplishments.
- **Camaraderie** – Having warm, interesting, and cooperative relations with others in the workplace; achieving a sense of community, belonging, and collegiality.
- **Equity** – Being treated justly in relation to the basic conditions of employment with respect to others in the organization as well as minimum personal/societal standards.

3. Developing the Conceptual Framework

The literature show far reviewed is obtained from various organisations. Most researches emphasize merely the importance and positive impacts of employee engagement on the business outcomes, failing to provide the barometer to measure the level of employee engagement. Engagement activity decision should be evaluated in terms of how effectively it will increase the level of engagement. Drawing from practitioner and academic research, the following new employee engagement framework has been sketched in this study. This framework offers a new measure of employee engagement, along with its antecedents and outcomes. Such a framework will enable organizations to better understand how engagement may vary by employee or group and identify

the key drivers that influence engagement. Most importantly, the linkages between employee engagement and business outcomes can also be assessed.

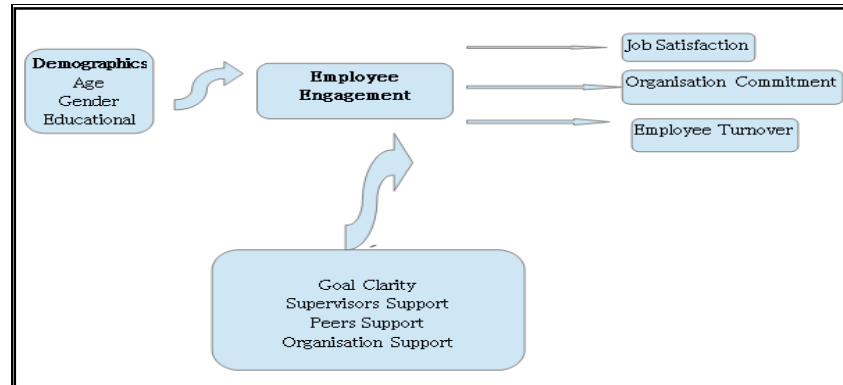

Figure 5: Conceptual Framework

3.1. Role Clarity ,Relationship with Peers and Managers and Engagement

Various research work has also suggested that when goals are cascaded from organisation level to individual levels leads to goal clarity of an individual which leads to an engaged employee.(Rebecca McNeil2012).Employees when start doing the work of the peers and their managers will create engaged employees and it will be difficult for employers to replace these employees.The relationship with peers and the managers would lead an employee to move beyond his job responsibilities.(Theresa Melbourne,2003).precipitate of personal needs, able to spend time with family, Scope for Advancement and Career Growth (well designed policy, adequate opportunities for career growth and advancement, clearly laid down career growth paths; implementation of the promotion policy in a fair and transparent manner, help to the employees in achieving growth) . Several other researches also reflect that while organisations consider both financial and nonfinancial tools for attracting,engaging, and retaining employees, it would be a mistake to conclude, based on general surveys, that monetary rewards are not highly important.Compensation should take into account both pay variability for the specific job position across the industry and the individual performance only then it will be an apt factor which can lead to engagement(Saral R Rynes 2004).Involvement of people in the goal setting process,frequency of appraisal and how appraisal is tied with thepersonal development plan plays a vital role in the engagement process (Elane Frnadell et al 2011).

3.2. Engagement and Organisation Support

The study conducted by (A.Gokul, G.Sridevi & Dr.P.T.Srinivasan 2012) has exhibited that positive organizational support through employees' dedication is important for them to be affectively committed to their organization. Research has well established that committed employees are better performers. Hence organizations need to strive better to provide a supportive climate for their employees to be better committed and hence perform better.Hence in this conceptual framework we have used Organisation Support as one of the drivers of employee engagement.

3.3. Engagement and Employee turnover

Employee retention and turnover are actually the opposites of the same thing.Employee retention means the number of employees continuing to serve the organization,and employee turnover refers to the amount of employees leaving the organization due to different reasons.To state it differently in most of the organizations the re-ention of employees is desired and turnover is usually not under control and undesired.(Phillips and Connel, 2003).Ivanovic (2007, p. 227) presents a definition of retention by The Dictionary of Human Resources and Personnel Management, that retention is "the process of keeping the loyalty of existing employees and persuading them not to work for another company '...a systematic approach to human resource planning can play a significant part in reducing recruitment and retention".

3.4. Engagement and Job satisfaction

Low engagement and job satisfaction can contribute to multiple organizational problems and have been associated with increased levels of turnover and absenteeism, adding potential costs to the organization in terms of low performance and decreased productivity. It is important for HR professionals to be aware of the needs and makeup of their workforce, as well as the impact of environmental factors, when developing their programs and policies. As the job market expands, it will be particularly important for HR professionals to pay close attention to aspects that are engaging their workforce and important to employee job satisfaction—including specific differences by employee demographics such as age, gender or tenure.(SHRM 2012).

3.5. *Engagement and Commitment*

In this business environment employees and employers have traditionally made a tacit agreement: In exchange for workers' commitment, organizations would provide forms of value for employees, such as secure jobs and fair compensation. Reciprocity affects the intensity of a commitment. When an entity or individual to whom someone has made a commitment fails to come through with the expected exchange, the commitment erodes. (Robert J Vace SHRM 2012)

3.6. *Engagement and Employee turnover*

Similarly, employee retention is an issue for the private and public sector alike. Right Management (2006) found that 75% of engaged employees planned to stay with the organisation for at least five years, whilst only 44% of non-engaged employees planned to stay. On this issue Towers Perrin (2003) also found that a highly engaged workforce is a more stable workforce – in their survey two thirds of highly engaged employees had no plans to leave their jobs versus just 12% of the disengaged. According to Towers Perrin (2003), whilst high engagement does not guarantee retention, it does increase the chances of retaining the very people who are probably going to be most attractive in a competitive labour market. With regard to retention, Towers Perrin (2003) highlights an important impact related to the disengaged. Whilst organisations can potentially lose key employees through not successfully engaging them, there is also a risk to the organisation from the disengaged who are not actively looking for other employment and continue in their current employment but are disaffected and unproductive. Towers Perrin (2003) note that retaining the disengaged can have as serious consequences for performance as losing the highly engaged.

3.7. *Managing Employee Engagement for Gen X and Gen Y*

In the age of changing tectonics today's workplace has a challenge to deal with the generational diversity. Each of the generations demand their own take aways from the organisation.

Generation can be defined as a cohort which comprises of individuals of same age who share the social, economic and historical experience within the same time period (Ryder, 1965). Members of the same cohort share important life experiences such as completion of schooling, graduating and entering the workforce, and retiring at similar age (Kowske et al., 2010).

Baby Boomers (Boomers) (born from 1946 to 1964) who comprise the largest generational cohort about 78 million workers belong to this cohort who have made great social and economic impacts and are now being replaced by younger generation, Millennials. Boomers are more driven by work goals, tasks and results in the workplace, showing a higher desire to enter into positions with greater responsibility and fame. (Families and Work Institute, 2006). Boomers have the belief that hard work is always paid back and have expectations to be rewarded and are comparatively more loyal and committed to the organisations than the millennials (Gursoy, Maier, & Chi, 2008; Smola & Sutton, 2002). Baby boomers are currently the largest generation of active workers. Research has shown that boomers identify their strengths as optimism, and their willingness to work long hours. This generation grew up in organizations with large hierarchies, rather than flat management structures and teamwork-based job roles.

Millennials (Generation Y or GenMe) (born from 1981 to 1999) are the youngest generation cohort, Millennial generation has been characterised by economic prosperity, advancement of instant communication technologies through the Internet, social networking, and globalization, who need more balance between work and life, flexibility in job assignments and want to define the exact role in their job. Millennials value freedom and work-life balance more than Baby Boomers (Cennamo & Gardner, 2008; Smola & Sutton, 2002; Twenge, 2010). They value high leisure work values, preferring a job that provides more vacation time (Twenge et al., 2010). Millennials have higher expectations about promotions and pay raises in the workplace (Ng et al., 2010). They do, however, realize that their need for social interaction, immediate results in their work, and desire for speedy advancement may be seen as weaknesses by older colleagues. Not tolerant of less challenging work (Corporate Leadership Council, 2005; Lancaster & Stillman, 2002). Millennials are usually multi skilled and prefer to work in teams and a flat structure. Contemporary organisations are facing the challenge to manage engagement and retain Gen Y and Gen X. Organizations have engagement tools that typically address engagement for the organization under one basket without any differentiation for the generations of employees. As the millennial generation will start entering into the work force rapidly and baby boomers will retire new engagement models need to be developed to address the differences between baby boomers and millennials.

4. Conclusion

As the work environment becomes mobile dispersed and diversified it becomes all the more vital and the sometime challenging to keep people engaged. Executives need trusted communication regarding the goals that they have to play and support both from managers and peer group to achieve their key result areas and at the same remain highly enthusiastic about their work. Engaged employees stay for what they give to the organization, whereas the disengaged stay for what they get from the organization. The above conceptual frame work will serve as a guide line to measure engagement and its business impact.

5. References

1. Allen, N. and Meyer, J. (1990). 'The measurement and antecedents of affective, continuance, and normative commitment to the organization'. *Journal of Occupation Psychology*, 61: 1, 1–18.
2. Bridge Consulting-Business Case for employee engagement and communication
3. Boshoff, C., & Allen, J. (2000). Kahn, W, 1990, 'Psychological Conditions of Personal 22 Raja, U, and F Ntalianis, 2004, 'The Impact of Personality on Engagement and Disengagement at Work', *Academy of Psychological Contracts*, *Academy of Management Journal, Management Journal*, Vol 33, No 4, p 6
4. Bernthal, P. R. (2004). *Measuring employee engagement*. Development Dimensions International, Inc. Retrieved January 7, 2008,
5. Cennamo, L., & Gardner, D. (2008). Generational differences in work values, outcomes and person-organisation values fit. *Journal of Managerial Psychology*, 23(8) Department of Psychology, Stockholm University, ISBN 91-7155-171-9.
6. Dr Elaine Farndale, Dr Veronica Hope Hailey, Dr Clare Kelliher, Dr Marc van Veldhoven (2011). *Final Report :A study on the link between Performance Management System and Employee Engagemnt in Western Multinational corporation operating in India and China*
7. Wittig-Berman, U. (2008). Work-family conflict and work-family synergy for generation X, baby boomers, and matures. *Journal of Managerial Psychology*, 23(5), 507.
8. Fernando, Y., Mat Saad, N. And Haron, M.S. (2012), "New marketing definition: a future agenda for a low cost carrier airlines in Indonesia", *Business Strategy Series*, Vol. 13 Issu: 1, pp.31-40.
9. Gursoy, D., Maier, T. A., & Chi, C. G. (2008). Generational differences: An examination of work values and generational gaps in the hospitality workforce. *International Journal of Hospitality Management*, 27(3), 448–458.
10. Hackman, J. R., and Oldham, G. R. (1980), *Work Redesign*, Reading: Addison-Wesley.
11. *HR'S Role in employee engagement 2012*
12. Humphrey, S. E., Nahrgang, J. D., and Morgeson, F. P. (2007) 'Integrating Motivational, Social, and Contextual Work Design Features: A Meta-Analytic Summary and Theoretical Extension of the WorkDesign Literature,' *Journal of Applied Psychology*, Vol. 92, pp. 1332-1356.
13. Hurst, J.L. and Good, L.K. (2009), "Generation Y and career choice: the impact of retail career
14. perceptions, expectations and entitlement perceptions", *Career Development*
15. *International*, Vol. 14 No. 6, 2009. pp. 570-593
16. Joshi, R. J. and Sodhi, J. S. (2011). Drivers of Employee Engagement in Indian
17. Organizations, *The Indian Journal of Industrial Relations*.47(1)
18. Jeongdoo Par & Dogan Gursoy) Generation Effect on the Relationship between Work Engagement, Satisfaction, and Turnover Intention among US Hotel Employees
19. Kahn, W.A. (1990). 'Psychological conditions of personal engagement and disengagement at work'. *Academy of Management Journal*, 33: 4, 692–724.
20. Lieber, L.D. (2010). How HR Can Assist in Managing the Four Generations in Today's
21. Workplace. *Employment Relations Today*, 36(4), 85-91.
22. Mohapatra, M. & Sharma, B.R. (2010), "Study of Employee Engagement and Its Predic-tors in an Indian Public Sector Undertak-ing," *Global Business Review*, 11 (2): 281 -301.
23. Martin, C. A. (2005). From high maintenance to high productivity: What managers need to know about Generation Y. *Industrial and Commercial Training*, 37(1), 39-44.
24. Norman B Ryder (1965) *American Sociological Review* Vol-30, No 6
25. Saral, R Rynes (2004) Importance of pay as an motivator: Discrepancies between what people say and what they do. *Human Resource Management*, Winter 2004, Vol. 43, No. 4, Pp. 381–394
26. Saks, A. M. (2006). Antecedents and consequences of employee engagement. *Journal of Managerial Psychology*, 21, 7, 600-619.
27. Theresa Melbourne (2003) *Employee Engagement -Doing it Vs Measuring*, HR.com
28. Twenge, J. M. (2010). A review of the empirical evidence on generational differences in work attitudes. *Journal of Business and Psychology*, 25(2), 201–210.
29. Thomas, C. H. (2006). Clarifying the concept of work engagement: Construct validation and an empirical test. Unpublished doctoral dissertation, The University of Georgia, Athens.
30. Working today: Understanding what drives employee engagement, The 2003 Hallberg, U. E. (2005). A thesis on fire: Studies of work engagement, type a behavior and burnout.
31. Wright, T.A. and Cropanzano, R. (2000). 'Psychological well-being and job satisfaction as predictors of job performance'. *Journal of Occupational Health Psychology*, 5: 1, 84–94.
32. Xanthopoulou, D., Bakker, A.B., Demerouti, E. & Schaufcli. W.B. (2009), "Work Engagement and Financial Returns: A Diary Study on the Role of Job and Personal Resources,"
33. *Journal of Occupational and Organizational Psychology*. 82: 183-200