

THE INTERNATIONAL JOURNAL OF BUSINESS & MANAGEMENT

Authenticity Perception in Local Product Shopping Intentions: An Empirical Study of Hand Drawn and Stamped Batik

Ratna Roostika

Senior Lecturer, Department of Management, Universitas Islam Indonesia, Indonesia

Abstract:

The purpose of this research is to analyze the shopping behavior of tourists when travelling, particularly towards the local arts and crafts products. Product authenticity is built as a multidimensional variable consisting of quality commitment, heritage and uniqueness. It is believed that tourists shopping behaviors is different from the daily shopping behaviors. Tourists highly appreciate authenticity and willing to pay high for authentic product. Quantitative approach is chosen to achieve the research objective. 189 valid questionnaires were used for further statistical analysis using PLS-SEM technique. The findings show that quality commitment, heritage and uniqueness are dimensions that built product authenticity. This study also found that product authenticity positively impact on behavioral intentions. The implications are particularly to suggest tourism and marketing managers as well as the government in giving focus on exploring authenticity for creating differentiation and building marketing positioning strategy.

Keywords: Product authenticity, behavior intentions, tourism shopping, batik arts

1. Introduction

Tourism has grown rapidly and has becoming the center of attention because of its wide impacts on other industries. The increasing wealth, education and technology have made people travelling more and seek for something different, particularly things they cannot find in their home countries. When travelling, finding something unique can be very pleasurable. Tourists often willing to pay high for products or services they belief to have uniqueness or authentic values. Increasing public access on information technology makes people find information sources more easily. Information technology does make people more aware on the issues from local to global scope. People are becoming more aware on the environmental issues, politic and cultural diversity. Related to tourism industry, awareness for cultural diversity and the quest for authenticity increase rapidly (Gilmore and Pine, 2007; Okumus, et al., 2007). This trend has made marketers consider authenticity as a marketing tool or even brand-positioning strategy to increase tourism positioning (Robinson and Clifford, 2012). In the tourism sector 'authenticity' has been incorporated in the marketing strategy as a unique selling point.

Considering that competition in the tourism sector is intensifying and every country or region must find their own tool to win the market, authenticity is increasingly used as product and service strategy as well as brand positioning strategy (Sedmak and Mihali, 2008; Robinson and Clifford, 2012). Both academics and practitioners have acknowledged the role of authenticity for product positioning and consumer behavior (Newman and Dhar, 2014). The marketers concern on authenticity has been strengthen by Gilmore and Pine (2007) in Assiouras et al., (2015) by stating that "authenticity has overtaken quality". When market condition changes, market are more informed and more buying power, then market will consider more than just quality. In the tourism sector, similarly, the trend on originality and authenticity should be translated into marketing strategy in align with local or regional uniqueness.

Shopping is one of most important tourism activities. Travelers spend significant amount of their money for shopping tourism products such culinary, entertainment, local experience, souvenirs, etc. Batik is one of most favorite products seek by tourists when visiting Indonesia. It is a local fabric drawn manually with wax. The quality of Batik commonly determined by its originality or authenticity and its further determine the price. The growing attention on authenticity perception so far has not been studied in the tourism sector particularly in Batik industry. Study on authenticity in Batik industry is important due to its complexity in the making, the skills required as well as the history that Batik has for Indonesian. Thus, study relating to authenticity in the Indonesian Batik industry needed to be further explored. The objective of this study is to analyze how product authenticity will impact on customer behavior intentions. In particular, product authenticity will be explored in terms of its quality aspect, heritage and uniqueness. It is expected that exploring the nature of authenticity in Batik could assist the Batik industry to define their marketing strategy align with the authentic values unique to the region and the Batik per see.

2. Literature Review

2.1. Indonesia Batik History

Batik has been part of Indonesia's long cultural history. The development of batik has been influenced by Hindu, China and European cultures and has been known since the 4th or 5th century. For the Javanese, batik has a special philosophy and the design has many symbols representing the human cycle. Thousands of batik designs have been produced and motifs taken from the nature such as the animals, leaves, flowers, clouds, are the most common. In Javanese, batik came from the word 'amba' which means 'to write'. There are three techniques for making Batik which cover 1) hand-drawn batik, 2) hand-stamped batik, and 3) a combination of hand drawn and hand stamped. As an art and craft products, the work on Batik emphasize manual or handmade talents where authenticity is highly appreciated. The detail and the complexity on the making determine the price. When shopping for Batik, the authentic design associated with the origin is very important. Batik production are spread mainly in Java particularly around Surakarta, Yogyakarta, Pekalongan, Cirebon, and Lasem. The spread of Batik in the global market was initiated by the Dutch colony. After the independence, Indonesia has exported Batik such as to the U.S., Netherland, France, Germany and Arab Emirates (Kemendag, 2012). In the 2nd of October 2009, UNESCO gave approval for Indonesia Batik as a Masterpiece of Oral and Intangible Heritage of Humanity. Since then, the 2nd of October has been celebrated as Batik day.

After being announced as cultural heritage by UNESCO in 2009, the popularity of Batik increasing sharply. Not only the old generation but the young generation also in favor of wearing Batik. Since then, Batik market becomes very attractive. Indonesian Export on Batik shows an increasing trend while import batik also increasing from USD 28 million in 2014 to USD 34 million in 2015 (Budiman, 2016). It has been recorded that the market attractiveness has caused the inflow of import Batik mainly from China and Malaysia called "Batik printing". The presence of Batik printing certainly worries the local hand drawn and stamped Batik producers. Indonesians do not regard Batik printing as Batik since it is a common textile with Batik motif made by manufacture. However, the middle low-end market still considers the price as the most important consideration for purchasing Batik, so this Batik printing really takes the market share who demand low price. This situation urges the government and the local handmade batik producers to protect as well as to facilitate the competition of the local Batik artisans. Authenticity, uniqueness, trade mark and intellectual property right are among some weapons to face Batik printing. Fortunately, many tourists (local or international) are still consider that the authenticity and uniqueness are important factor when buying Batik. The government and Batik producers need to maintain the middle up segment since they see Batik as art and craft products where authenticity must be strong. For this segment, the market appreciates the value of authenticity and consumers would pay high for authentic products (Moulard, et al. 2015).

2.2. Product Authenticity

Authenticity is a word where originally came from the Greek word *authentikos* (Assiouras, et al., 2015). In a Latin word, *authenticus* means trustworthy. As a concept, authentic city has been translated differently either in different meaning or in different ways (Lu, et al., 2015; Napoli, et al., 2014). Authenticity in today's literature has commonly explain the genuineness of the object, the reality of something or the truth about something (Lu, et al., 2015). Others have defined authenticity as something that has sincerity, something with innocence, and something original (Fine, 2003). Authenticity also refers to naturalness, honesty and simplicity (Assiouras, et al., 2015). In business, consumers have different interest, therefore authenticity is differently perceived. People with different knowledge, different background and different culture have different way in evaluating authenticity. Consumers use different range of cues to evaluate authenticity to an object. In the tourism industry, the willingness to travels away from home can be motivated by the authentic and unique offerings by the destination. It is believed that authenticity is an important determinant for tourists' motivation to visit. Kolar and Zabkar (2010) argue that authenticity is considered as a universal value and a critical driving motivation for tourists in travelling decisions. Tourists have different shopping behavior compared to day to day shopping activities. Tourists appreciate authentic goods and experiences that they cannot find from their daily routines. When tourist belief that the products offer authenticity, they will pay high.

Within the discipline of marketing, authenticity has been studied within several structural model. Authenticity is commonly discussed in terms of brand with only few discussing on product authenticity. Morhart, et al., (2015) developed a structural model explaining the antecedent and consequences of brand authenticity. Specifically, Morhart et al., (2015) integrative model relates brand authenticity and brand equity. Morhart, et al., (2015) authenticity model was expected to give theoretical foundation for perception of a brand as authentic. Other studies have treated authenticity as a mediator between variables such as liking, perceived value, perceived quality, residents support and purchase intention (Starr, 2011; Zhou, et al., 2015).

In order to be considered as having authentic value, Morhart, et al., (2015) offer various dimensions, which consist of indexical cues, iconic cues, and existential cues. Napoli, et al., (2014) study on the other hand offer usable measurement scale for authenticity. They argue that product authenticity can be measured from three dimensions which include: the quality commitment, the sincerity and the heritage. In align with Batik as the object of this study, Napoli, et al., (2014) dimensions representing product authenticity are used. The quality commitment, the sincerity and the heritage are dimensions that are closely related with Batik as cultural product for the Javanese.

2.3. Behavioural Intentions

In order to gain success in tourism shopping, government and tourism agencies should consider the intention - behaviors theories. These theories will help to understand what motive behind people decision to shop or to

purchase. According to Theory of reasoned action (TRA), Fishbein and Ajzen (1975) argue that individual's behaviors can be determined by their intentions. Ajzen and Fishbein (1980) further explain that behavioral intentions refers to how people's beliefs about intention they decide to take in a certain situation. There are favorable behavioral intentions which include consumers' intention to say positive things, to remain loyal, to recommend to other customers, to spend more with the organization and to pay price premiums. The intention-behavior theories have been empirically validated in the tourism and hospitality sectors such as tourists' intentions to visit a place or destination (Shen, et al., 2009); Yamada and Fu, 2012) and intentions for medical tourism (Lee, et al., 2012).

In the tourism sectors where majority of the offerings are intangible in nature, tourists often rely on other people review or suggestion. In the service business, direct Word-of-mouth (WOM) communication is believed to be more effective than using other promotions. This is because tourists can only have the experience after they came to the site. In this situation, since the total cost is expensive and the risk is big, thus tourists prefer to have opinion or suggestions from someone who already have the real experiences. Wang, et al., (2017) explain that WOM is "an informal, person-to-person communication between a perceived non-commercial communicator and a receiver regarding a brand, a product, and organization, or a service". WOM is also define as sharing experiences to others, where communication developed may influence someone for buying decision (Virvilaite, et al., 2015). It is important to note that positive WOM should encourage people to stay loyal, however, for some travelers, they do not comeback to previous shop only because they always want to experience new and different things.

2.4. Product Authenticity and Behavioral Intentions Relationships

Since authenticity became a concern for brand positioning and marketing strategy, an integrative framework was built to explain how authenticity may influence brand equity. Antecedents and consequences of brand and product authenticity was built in structural model to further explore the role of authenticity. As previously discussed, product authenticity is a multidimensional construct. According to Napoli, et al., (2014), product authenticity is best to be measured with three dimensions that are quality commitment, heritage and sincerity. Assiouras, et al., (2015) study have modelled product authenticity as a reflective model and product authenticity is both directly and indirectly influence behavioural intentions. Measured as multidimensional model with quality, heritage and uniqueness, authenticity may entail positive responses by consumers (Morhart, et al., 2015). Zhou, et al., (2015) study in tourism also have evidenced on the objective and existential authenticity on behavioral intentions particularly on resident supports. Therefore, this study proposes that:

- H1: Product authenticity has a positive impact on purchase intentions in Batik shopping.

3. Research Methodology

3.1. Research Design

This study applies quantitative methodologies to investigate the relationships between product authenticity and Batik purchase intentions. In order to attain the objective of the study, questionnaires were developed and distributed in selected areas particularly in Central Java and Yogyakarta. Given the multivariate nature of the model Structural Equation Modelling (SEM) was employed using PLS (Partial Least Squares). Product authenticity is designed as second order model which is measured by product quality, heritage and uniqueness. A two-step approach as recommended by Anderson and Gerbing (1988) was applied where measurement model is tested before further running structural model. Measurement model is analyzed to ensure validity and reliability. Whereas, the structural model is to analyze the relationship between exogen and endogen variable (product authenticity and purchase behaviors relationships).

The structured questionnaire was applied and Likert scaling was used ranging from strongly disagree (1) to strongly agree (5). The questionnaires were developed from the previous literature. Product authenticity measure was developed from Assiouras et al., (2015) and Napoli et al., (2014), for example "Quality is central to the product", "The product has a strong connection to an historical period in time, culture and/or specific region", and "The product remains true to its espoused values". Purchase intentions measure were developed mainly from Assiouras. et al., (2015) and Park, et al., (2010) studies, for example "I would be happy to recommend this product to others" and "I like to buy this product in the future".

Variable	Range	Percentage	Range	Percentage
Gender	Female	55%	Male	45%
Age	< 20	47.6%	31-40	6.3%
	21-30	32.3%	>40	13.8%
Education	High School	24.3%	Post Graduate	20.6%
	Bachelor	54.5%	Other	5%
Occupation	Students Post grad	59.8%	Self employed	7.9%
	Private	20.1%	Other	10.6%
	Civil	1.6%		
Reason to buy	Motif	29.1%	Low price	7.9%
	Quality	25.9%	Color	11.6%
	Originality	25.9%		

Table 1: Characteristics of Respondents

4. Data Collection and Analysis

Table 1 shows respondents' characteristics. This research applies purposive sampling where respondents should be those who have purchased Batik particularly hand drawn Batik or stamped Batik. The questionnaires were distributed around Central Java and Jogjakarta provinces where there are many Batik centers. Online and offline survey were conducted, and after checking the missing values, 189 were used for further statistical analysis. There were 55% female respondents and 45% male respondents participating in this survey. Majority of respondents are in the age range between less than 20 to 30 years old. Post graduate students and those who works in private sectors made the most participant according to occupations representing almost 80% of the respondents. There are also some interesting findings where the most common reason for buying Batik is because of the Motif accounting for 29.1%. The reasons for Batik are then followed with Quality 25.9%, originality 25.9%, low price 7.9% and color 11.6%.

4.1. Assessment of the Measurement Model

As previously stated, PLS-SEM modelling was chosen to estimate the validity and reliability also to test the proposed hypotheses. Smart PLS software was developed by (Ringle, et al., 2015). And has been increasingly popular as statistical tool among researchers in the, hospitality and tourism research (Ali, et al., 2018). This study uses PLS-SEM due to its ability to test the existence of second order variable that exist in the proposed research model. In running PLS analysis, this study follows the suggestion from Hair, et al. (2014) where a two-step approach is taken. The two step approaches cover the measurement model assessment to test the validity and reliability, then followed by the structural model assessment to test the hypothesis. The measurement model in this study will discuss the cross-loading, the composite reliability, AVE and square root AVE.

Convergent validity can be measured with cross loadings, average variance extracted and composite reliability. Table 2 shows the AVE, composite reliability and Cronbach's Alpha. PLS analysis has given the results where the composite reliability index for all key constructs were above the minimum acceptable value of 0.7. Quality commitment shows the highest value with 0.9446 and heritage shows the lowest value of 0.9155. The Average Variance Extracted (AVE) indicates satisfactory value where all above the threshold value of 0.5, this suggest that the measures have adequate convergent validity.

	AVE	Composite Reliability	R Square	Cronbach's Alpha	Communality	Redundancy
Behavior Intentions	0.6464	0.9358	0.5178	0.9216	0.6464	0.3293
Heritage	0.7304	0.9155	0.6609	0.8768	0.7304	0.4811
Product Authenticity	0.5664	0.9513	0	0.9448	0.5664	0
Quality Comm	0.709	0.9446	0.8701	0.9314	0.709	0.6164
Uniqueness	0.753	0.924	0.749	0.8894	0.753	0.5621

Table 2: AVE, Composite Reliability and Cronbach Alpha

Table 3 shows the cross-loadings indicators where indicators of a variable should load to the related variable higher than other variables. Cross loadings provide identification of convergent validity. Internal consistency reliability is shown by both Composite Reliability (CR) and Cronbach's Alpha where all the values show well above the suggested threshold of 0.7.

	Behavior Intentions	Heritage	Quality Commitment	Uniqueness		Behavior Intentions	Heritage	Quality Commitment	Uniqueness
B1	0.8282	0.4592	0.6255	0.5355	K5	0.6103	0.5935	0.8007	0.5712
B2	0.8455	0.5002	0.617	0.5912	K6	0.5851	0.5624	0.8387	0.5867
B3	0.8655	0.4423	0.6127	0.5517	K7	0.559	0.5574	0.839	0.5866
B4	0.7306	0.3555	0.4017	0.4338	NW 1	0.3856	0.8569	0.5142	0.4956
B5	0.8246	0.5197	0.5995	0.5987	NW 2	0.4718	0.878	0.512	0.5348
B6	0.8005	0.3633	0.484	0.452	NW 3	0.4724	0.8461	0.5133	0.5419
B7	0.7832	0.4201	0.5199	0.5332	NW 4	0.4921	0.837	0.6064	0.5269
B8	0.7437	0.3245	0.4387	0.4772	U1	0.5305	0.4547	0.5132	0.8138
K1	0.5628	0.4718	0.8519	0.5815	U2	0.5579	0.5589	0.6549	0.9277
K2	0.5732	0.5085	0.8845	0.6066	U3	0.5813	0.5636	0.6382	0.9067
K3	0.5692	0.5345	0.849	0.6028	U4	0.6026	0.547	0.6317	0.8167
K4	0.5398	0.4793	0.8281	0.6233					

Table 3: Cross Loadings

Next, discriminant validity was assessed. Table 4 shows that the square root of each AVE (shown on the bold diagonal value) is greater than the correlation between related inter-construct in the construct correlation table. This AVE square root indicates the evidence of the discriminant validity for all the reflective constructs proposed in the model.

	Behavior Intentions	Heritage	Quality Commitment	Uniqueness
Behavior Intentions	0.80399	0	0	0
Heritage	0.5342	0.8546	0	0
Quality Commitment	0.6787	0.6292	0.842	0
Uniqueness	0.6547	0.6145	0.7057	0.8677

Table 4: AVE Square Root

4.2. Assessment of the Structural Model

Smart PLS version 3.0 was used to test the structural model and hypotheses. A bootstrapping procedure with 2.000 iterations was performed to examine the statistical significance of the path coefficients. Here the bootstrapping procedure was conducted to calculate the significance of path relationships.

	Original Sample (O)	Sample Mean (M)	Standard Deviation (STDEV)	Standard Error (STERR)	T Statistics (O/STERR)
Prod Authenticity -> Behavior Intent	0.7196	0.7204	0.0526	0.0526	13.6889
Prod Authenticity -> Heritage	0.813	0.8122	0.0413	0.0413	19.6751
Prod Authenticity -> Quality Comm	0.9328	0.9314	0.0166	0.0166	56.3241
Prod Authenticity -> Uniqueness	0.8655	0.8605	0.0341	0.0341	25.3646

Table 5: Path Coefficients

By using the valid and reliable data taken from the measurement model, the hypothesized relationships among the constructs can be identified. The structural model was evaluated by examining the path coefficients, t-statistics and r-squared value (Chin, 1998). According to table 5 and Figure 1, we can see that product authenticity was well explained by Quality commitment, heritage and uniqueness. Quality commitment has the strongest path coefficient which was 0.93. Heritage was 0.813 and uniqueness was 0.865. The results of t-statistics were shown in Table 5 where all the relationships values were above 1.96. Finally the r-squared value also shows satisfactory strong results where quality commitment is 0.870, heritage is 0.661 and uniqueness is 0.865. The hypothesis testing can be answered by the significant of the path coefficient between product authenticity and behavioral intentions. Here the impact of product authenticity and behavioral intentions is 0.720 which is considered strong. This finding thus supports the hypothesis of this study where "Product authenticity has a positive impact on purchase intentions in Batik shopping".

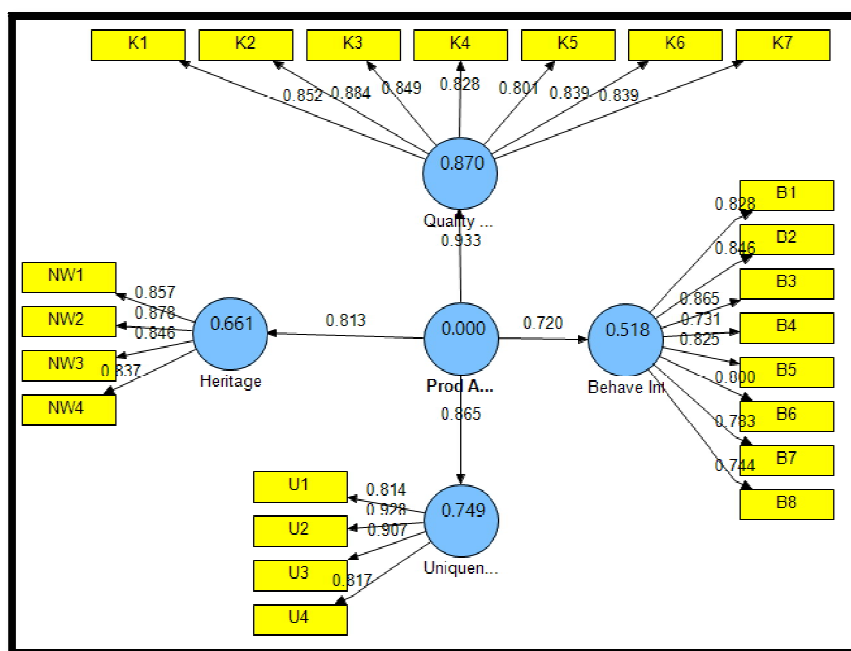

Figure 1: The Final PLS Output

5. Discussion and Implication

When shopping as part of travelling activities, people have attitudes and behaviors different from when they shop in their everyday life. In order to reach the destination areas, people often travel far away and spend lots of money to find and to experience something unique which cannot be found in their home country. It is why tourists have higher level of tolerance for the higher price of goods and services offered in the tourism centers. It was said that tourists spending in the destination areas are less price elastic than spending for their daily life. This study supports the hypothesis where "Product authenticity has a positive impact on purchase intentions in Batik shopping". This finding strengthens the previous research findings such as Assiouras, et al., (2015); Morhart, et al., 2015; Napoli, et al., (2014) and Zhou, et al., (2015). There has not been any study focusing the element of product authenticity and its relationship to tourists' behavior intention. Batik is an art crafts and manually made. Therefore the authentic values are really strong and determine the quality and price. The study on the different behaviors of tourism shopping and the case of Batik shopping enrich the literature on product authenticity study and marketing literature. Managers and policy makers in tourism area should consider the unique behavior of tourism shopping also the role of all dimensions that build product authenticity as a tool to differentiate tourism strategy.

6. Conclusion and Recommendation

People are travelling a lot more nowadays. Technologies have made travelling easier and information is widely accessible. One of the most favorite tourism activities is shopping. The behavior of tourism shopping is different from the shopping behaviors of daily life. It is believed that tourism shopping is less price-sensitive and tourists highly value the authenticity. Product authenticity thus can be used as a tool to build marketing strategy in tourism sector and differentiation from the competitors. This study shows that product activities have positive impact on behavior intention in batik shopping. This means that product authenticity in terms of quality commitment, heritage and uniqueness should be carefully managed in order to create positive tourists behavior for shopping. This study has suggestions for future research that the elements of product activities could be expanded. The model relating product authenticity to behavior intentions can also improved by the evaluation of other antecedents variable such as trust, image or brand equity. For the managers in tourism sector, product authenticity should be taken as priority since authenticity can create unique differentiation and is also highly valued by visitors

7. References

- i. Ajzen, I. & Fishbein, M. (1980). *Understanding attitudes and predicting social behaviour*, Prentice-Hall, NJ.
- ii. Ali, F.S., Rasoolimanesh, M., Sarstedt, M., Ringle, C. & Ryu, K. (2017). An assessment of the use of partial least squares structural equation modelling (PLS-SEM) in hospitality research, *International Journal of Contemporary Hospitality Management*, <https://doi.org/10.1108/IJCHM-10-2016-0568>.
- iii. Anderson, J.C. & Gerbing, D.W. (1998). Structural equation modelling in practice: a review and recommended two-step approach, *Psychological Bulletin*, 103(3), 411-423.
- iv. Assiouras, I., Liapati, G., Kouletsis, G. & Koniordos, M. (2015). The impact of brand authenticity on brand attachment in the food industry, *British Food Journal*, 117(2), 538-552.
- v. Budiman, D. (2016). Karena Murah, Masyarakat RI Lebih Suka Batik Palsu Buatan China. Available at <https://economy.okezone.com/read/2016/02/25/320/1321075/karena-murah-masyarakat-ri-lebih-suka-batik-palsu-buatan-china>.
- vi. Chin, W.W. (1998). The partial least square approach to structural equation modeling, in GA Marcoulides (ed), *Modern methods for business research*, Lawrence Erlbaum Associates, Mahwah, NJ.
- vii. Fine, G.A. (2003). Crafting authenticity: the validation of identity in self-taught art, *Theory and Society*, 32(2), 153-180.
- viii. Fishbein, M. & Ajzen, I. (1975). *Belief, Attitude, Intention and Behavior: An Introduction to Theory and Research*, Addison-Wesley Pub. Co.
- ix. Gilmore, J. H., & Pine, B. J. (2007). *Authenticity: What consumers really want?* Boston: Harvard Business School Press.
- x. Kemendag. (2012). Batik cultural beauty. <http://www.kemendag.go.id/files/pdf/2012/12/08/batik-id0-1354950532.pdf>
- xi. Kolar, T. & Zabkar, V. (2010). A consumer-based model of authenticity: an oxymoron or the foundation of cultural heritage marketing? *Tourism Management*, 31(5), 652-664.
- xii. Lee, M., Han, H., & Lockyer, T. (2012). Medical tourism: Attracting Japanese tourists for medical tourism experience, *Journal of Travel and Tourism Marketing*, 29(1), 69-86.
- xiii. Lu, A.C., Gursoy, D. & Lu, C.Y. (2015). Authenticity perceptions, brand equity and brand choice intention: The case of ethnic restaurants, *International Journal of Hospitality Management*, 50, 36-45.
- xiv. Morhart, F., Malar, L., Gèvremont, A., Girardin, F. A & Grohmann, B. (2015). Brand authenticity: An integrative framework and measurement scale, *Journal of Consumer Psychology*, 25(2), 200-218.
- xv. Napoli, J., Dickinson, S.J., Beverland, M.B. & Farrelly, F. (2014). Measuring consumer-based brand authenticity, *Journal of Business Research*, 67, 1090-1098.
- xvi. Newman, G.E. & Dhar, R. (2014). Authenticity is contagious: Brand essence and the original source of production, *Journal of Marketing Research*, 51(3), pp. 371-386.
- xvii. Okumus, B., Okumus, F. & McKercher, B. (2007). Incorporating local and international cuisines in the marketing of tourism destinations: the cases of Hong Kong and Turkey, *Tourism Management*, 28(1), 253-261.

- xviii. Park, C.W., MacInnis, D.J., Priester, J., Eisingerich, A.B. & Iacobucci, D. (2010). Brand attachment and brand attitude strength: conceptual and empirical differentiation of two critical brand equity drivers, *Journal of Marketing*, 74(6), 1-17.
- xix. Ringle, C., Wende, S. & Becker, J., (2015). SmartPLS 3. Retrieved from. <https://doi.org/http://www.smartpls.com>.
- xx. Robinson, R.N. & Clifford, C. (2012). Authenticity and festival foodservice experiences, *Annals of Tourism Research*, 39(2), 571-600.
- xxii. Sedmak, G. & Mihali, T. (2008). Authenticity in mature seaside resorts, *Annals of Tourism Research*, 35(4), 1007-1031.
- xxiii. Shen, S., Schüttemeyer, A., & Braun, B. (2009). Vistors' intention to visit world cultural heritage sites: An empirical study of Suzhou, China, *Journal of Travel & Tourism Marketing*, 26(7), 722-734.
- xxiv. Starr, R. G. (2011). *The certification of authenticity: Effects on product perception*. New Zealand: The University of Auckland.
- xxv. Virvilaite, R., Tumasonyte, D., & Sliburyte, L. (2015). The influence of word of mouth communication on brand equity: Receiver perspectives, *Procedia-Social and Behavioral Sciences*, 213, 641-646.
- xxvi. Wang, T.L., Tran, P.T.K., & Tran, V.T. (2017). Destination perceived quality, tourist satisfaction and word-of-mouth. *Tourism Review*, 72(4), 392-410.
- xxvii. Yamada, N. & Fu, Y.Y. (2012). Using the theory of planned behavior to identify beliefs underlying visiting the Indiana State Museum, *Journal of Travel & Tourism Marketing*, 29(2), 119-132.
- xxviii. Zhou, Q., Zhang, J., Zhang, H. & Maa, J. (2015). A structural model of host authenticity, *Annals of Tourism Research*, 55, 28-45.