

THE INTERNATIONAL JOURNAL OF BUSINESS & MANAGEMENT

Determinants on E-Tourism Service Usage: An Empirical Investigation of Vietnam in Emerging Economies

Le Thai Phong

Professor, Foreign Trade University, Hanoi, Vietnam

Nguyen Thi Khanh Chi

Lecturer, Foreign Trade University, Vietnam

Abstract:

The development of IT and the Internet have provided opportunities for enterprises to change the way of doing business and to have competitive advantage over competitors. Nowadays, tourism enterprises in emerging countries are trying to utilise IT and the Internet in offering e-tourism services to customers, still at limited level. The study attempts to investigate the determinants on e-tourism service usage in Vietnam. Research methodologies use in this paper are qualitative and quantitative methods. Qualitative method is conducted by questionnaires from 10 tourists and 10 key managers coming from ten tourism enterprises to examine the factors affecting e-tourism service based on technology acceptance model (TAM) of Davis (1989). Quantitative research is qualified by a survey given to 417 tourists randomly selected. Data collected and examined by CFA and SEM through AMOS 20.0. The results showed that both perceived usefulness and perceived ease of use significantly and directly impacted their intention to use e-tourism services. Implications of this study are important for both tourism enterprises and government.

Keywords: e-Tourism, e-Tourism services, perceived usefulness, perceived ease of use

1. Introduction

Tourism sector has been transformed by the Information Communications Technologies ICT developments from conventional tourism to e-tourism (Buhalis and Jun, 2011). ICTs are important factors for economic development, especially for emerging countries such as Vietnam; and access to ICTs is considered a prerequisite for tourism enterprises and consumers participating in the digital economy (Mokraf, 2013). E-Tourism service was often related only to the web pages of travel agencies or aggregators offering many services; however, this is now referring to many applications and devices applied in tourism (Papińska-Kacperek, 2013). According to Iliachenko (2006), the most significant e-tourism services as professed by potential tourism service buyers are: Tourism information, Product information, online reservation and payment, Safety and security, Modified product search, Website interaction and direct links.

The tourism sector is rated among the top three product or service categories purchased via the Internet (Eric et al., 2006). With the world Internet users currently are approximately 4 billion accounted for 51.7 of the world population, leading a growth of 976.4 from the year of 2000 to 2017 (Internetworldstat, 2017). According to UNWTO, the international tourist in 2016 estimated at 1.235 billion turns, increased by 3.9% compared to 2015. This is the seventh year in a row that world tourism has maintained steady growth since the financial crisis, global economic recession in 2009. European remains the biggest market (619.7 million turns of tourists), following by Asia-Pacific (200.9 million turns) and Africa (58.2 million turns) (UNWTO, 2017). Thanks to ICT development, Vietnam ranks sixth in the list of the strongest tourist growth countries in 2017. In 2016, Vietnam welcomes 10 million international tourists and in the first four months of 2017, international arrivals to Vietnam increased by 31.2%, making Vietnam as the fastest growing travel market in Asia (UNWTO, 2017). Therefore, ICT development constantly makes tourism become the most economic resource for contributing to the development of Vietnam. However, what factors determine e-tourism service usage? There are few researches studied in identifying determinants on e-tourism service. Jain and Sharma (2013) showed that drivers affecting e-tourism service adoptability in India were utility, economic, reliability, efficiency, security. Souhani et al (2013) identified five other factors affecting e-Tourism in Iran which were hardware, software, information system, governmental and managerial policies, cultural and social factor. In term of the technology adoption, there are many researches showed variety of factors affecting like TAM of Davis (1989), IDT of Rogers (1995), TPB of Ajzen (1991), TOE of Tornatzky and Fleischer (1990) (Musawa, M.S. and Wahab, E., 2012). According to Park (2009), one of the well-known models related to technology acceptance and use is the technology acceptance model (TAM), originally proposed by Davis (1986). These models are popular and applicable in the West. They need to be retested in emerging markets for their validity. In light of this, the research is undertaken to study the determinants on e-Tourism services usage in Vietnam basing on TAM model provided by Davis (1989). Integrating theoretical framework of tourist acceptance and intention to use e-tourism service based mainly on TAM model. Thus, the detailed objectives of the paper are following:

- Identify determinants on tourist acceptance and intention to use Vietnamese e-tourism service
- Analysing relationship of tourist acceptance and intention to use e-tourism service with selected determinants
- Develop a structure equation model of e-tourism usage that provide tourism managers implications for better implementing e-tourism.

The remainder of this paper is organized into the following four sections. The first section provides a brief review of the literature, including the definition of e-tourism services, theoretical background of the technology acceptance model and studies about the relationship between selected factors with e-tourism service usage. Next, the research hypotheses are given out basing the theories in the preceding section. Then, we use CFA and SEM analysis via Amos 20.0 to test the proposed model, present the analysis and results of our study. Finally, conclusion by discussing the implications of our study is conducted, followed by presenting limitations and future research direction.

2. Literature Review

2.1. E-Tourism Service Usage

Cardoso et.al (2007) and Sebastian et al (2009) considered e-Tourism as an e-Tourism service, which are personal services and are created by an internal (supplier) and external (client) factors (Smith, 1994). This applies to all tourism services in accommodation, catering, travel agents, transport systems, and all other businesses related to the tourism value chain (Murphy et al., 2000). Similarly, according to Papińska-Kacperek (2013), e-Tourism service was often related only to the web pages of travel agencies or aggregators offering many services, whereas many applications and devices are applied in tourism.

Behavioural intention to use indicates the possibility that an individual will use an application (Ajzen and Fishbein, 1980). Agarwal and Prasad (1997) stated that behavioural intention to use is a technology adoption decision. Lin and Lu (2000) showed that intention is a measure of a person's willingness to use a Web site. Therefore, e-tourism service usage is considered as e-tourism intention to use which means a measure of tourists' willingness to use e-tourism services.

2.2. Technology Acceptance Model (TAM)

TAM has proven to be a theoretical model in helping to explain and predict user behaviour of information technology (Legris et al., 2003). TAM seeks to explain the relationship between individual's technological acceptance and adoption and subsequently, their behavioural intention to use it (Autry et al., 2010; Lee, Cheung and Chen, 2005; Ndubisi 2006; Maihotra and Galletta, 1999). The TAM model also suggests that perceived ease of use influences perceived usefulness, because technologies that are easy to use can be more useful (Schillewaert, N., Ahearne, M.J., Frambach, R.T. and Moenaert, R.K., 2005). Hence, it can be concluded that the TAM model has strong implications on technology adoption from theoretical and conceptual perspectives (Gangwar et al, 2013; Lee, Cheung and Chen, 2005).

2.2.1. Perceived Ease of Use

The definition of perceived ease of use is the degree to which a user believes that a particular technology will be free of effort (Davis et al., 1989, p.985). Davis et al. (1989) proceed that when a particular system is easy to operate, users are more likely to accept and use that system. The consideration of perceived usefulness has been widely recognised in the context of tourism industry. There are many researches indicated that perceived ease of use has strong impact on customers purchase intention (Davis, 1989; Lallamaho mood, 2007; Lee et.al, 2011, Chen et.al, 2013).

2.2.2. Perceived Usefulness

The definition of perceived usefulness is the prospective user's subjective probability that using a specific application system will increase his or her job performance within an organizational context (Davis et al., 1989, p.985). This definition points out that a user becomes aware that a particular technology is useful when the technology or system reduces the time it takes to do a job while simultaneously increasing efficiency and accuracy (Teo et al., 2008). Davis (1989) indicated that perceived usefulness strongly impact intention to use. Pavlou (2003) also investigated that perceived usefulness affects their behavioural intention to transact online. Similarly, Meuter et.al (2005) studied that perceived usefulness is a required condition to form an intention to use self-service technology.

2.2.3. E-Tourism Attitude

Attitude towards using refers to users' assessment of the desirability of using a specific information system's application (Ajzen and Fishbein, 1980). Agarwal and Prasad (1998) believed that attitude is a person's affective response towards using new technology. Therefore, e-Tourism attitude can be considered as a tourist's affective response towards using e-Tourism services. On the research of Al-kwifi (2015) about the impact of destination images on tourist, attitude has strong impact on tourist' intention. Stockdale (2006) also investigated that e-tourism attitude strongly effect intention to use e-tourism.

3. Methodology

3.1. Questionnaire Design

Qualitative method is conducted by questionnaires from 10 tourists including 5 international tourists and 5 domestic tourists and 10 key managers coming from ten tourism enterprises to examine the factors affecting e-tourism service usage based on based on technology acceptance model (TAM) of Davis (1989). The TAM proposed by Davis (1986)

had six constructs namely Perceived usefulness, Perceived ease of use, External variables, Attitude towards, Behavioural intention to use, Actual use. The factors effecting e-tourism service usage are selected in which external variables contained subjective norm, believe, system accessibility and other factors following the interviewee suggestion.

From expert interview, six factors were asked for the opinions of 10 tourist and 10 key managers, however, there were four among six factors selected. External variables and actual use in the case of Vietnam are not important factors, according to experts, affecting e-tourism service usage. They are only interested in the rest of four factors. It can be explained that not all e-tourism services in Vietnam have enough functions for tourists to book tours online or use tourism service on line, hence, tourists just stand at intention to use e-tourism services. Therefore, this study utilizes 4 out of 6 constructs suggested by TAM model. The research model is developed in the figure 1.

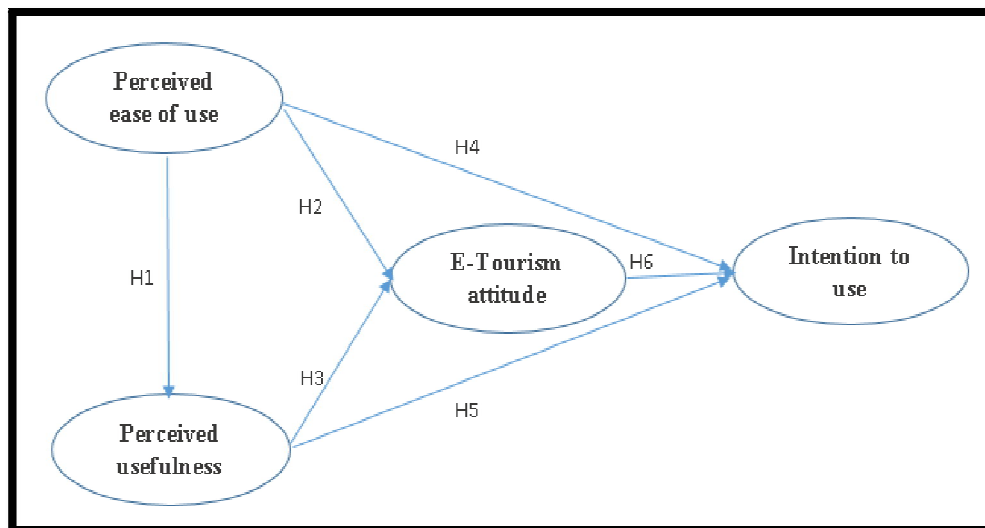

Figure 1: The Proposed Research Model

Base on the proposed research model, this study is going to test the following hypotheses:

- H1: Tourists' perceived usefulness is affected by their perceived ease of use
- H2: E-tourism attitude is affected by perceived ease of use
- H3: E-tourism attitude is affected by perceived usefulness
- H4: Intention to use is affected by perceived ease of use
- H5: Intention to use is affected by perceived usefulness
- H6: Intention to use is affected by e-Tourism attitude
- H7: Tourists' intention to use e-Tourism is affected by their attitude (H6), perceived usefulness (H5) and perceived ease of use (H4).
- H8: E-tourism attitude is affected by their perceived usefulness(H3) and perceived ease of use (H2)

The questionnaire with 20 items is designed as Table 1, based on the previous study. More 4 questions are added to identify demographic attributes of the respondents namely gender, age, transport, nationality. To ensure the face validity, we conducted a pilot test on 85 Vietnamese tourists at Hanoi capital. After the pilot test, some items were revised and the final questionnaire is presented as Table 1. The form of the questionnaires for tourist survey was determined by Google docs and hard copy delivered directly to individual tourists. The languages of questionnaires are set in three languages, English, Chinese and Vietnamese.

Construct	Item code	Item description	Source
Perceived ease of use (PE)	PE1	- It is easy to access tourism websites	Davis (1989); Lee, Cheung and Chen (2005); Park (2009)
	PE2	- Payments can be made easily	
	PE3	- It is easy to find what I want on online tourism service	
	PE4	- My interaction with online tourism service would be clear and understandable	
	PE5	- Online customer service is available all the time	
	PE6	- Learning to operate the online tourism system is easy for me	
	PE7	- The online tourism system is flexible to interact with	
Perceived usefulness (PU)	PU1	- Using online tourism services gives me greater control over my travel journey	Davis (1989); Lee, Cheung and Chen (2005); Park (2009)
	PU2	- Using online tourism services improves my journey	
	PU3	- Using online tourism services allows me to accomplish more work than would otherwise be possible	
	PU4	- Using online tourism services reduces the time I spend on unproductively activities	
	PU5	- Using online tourism services enables me to accomplish tasks more quickly	
	PU6	- Using online tourism services supports critical aspects of my journey	
	PU7	- Using online tourism services makes it easier to get information to travel	
E-tourism attitude (AT)	AT1	- Using online tourism services is a good idea	Lee, Cheung and Chen (2005); Malhotra and Galletta (1999)
	AT2	- Using online tourism services is a wise idea	
	AT3	- Using online tourism services is beneficial	
	AT4	- Using online tourism services is pleasant	
Intention to use (TU)	TU1	- I intend to use online tourism system for planning journey	Malhotra and Galletta (1999); Lee, Cheung and Chen (2005)
	TU2	- I intend to be a heavy user of online tourism system	

Table 1: Measurement Scale of Research

Respondents were asked to rate their opinion using a 5-point Likert scale ranging from 1=Strongly disagree, 2=Disagree, 3=No comment, 4=Agree and 5=Strongly agree.

3.2. Sample Size

The population in this research consist of international tourists travelling to Vietnam and Vietnamese tourists. According to Vietnamese National administration of tourism, there are 1.024.899 international arrivals estimated in October 2017 (statistics, 2017), and 57 thousand domestic trippers (statistics, 2015). In order to collect data, a random sample was conducted in this research. Simple random sampling method allows choosing single members randomly from a list of the customer who has a similar opportunity of selection. It is almost impossible to collect all tourists because there are a large number of tourists in Viet Nam and over the world. Therefore, random sampling method was necessary to select a small group from the list of all tourists. The sample size is 700 including international and domestic tourists.

There are 10 Departments of Culture, Sports and Tourism in Vietnam, however, 7 Departments are chosen for launching surveys such as Hanoi, Haiphong, Quangninh, Hue, Danang, Vung tau and Hochiminh city. In order to conduct random sample at 700, statistics distribution was conducted by 7 classes basing on 7 above Departments in which each Department carry out 100 surveys.

Online survey was mailed to 500 tourists at 6 places such as Haiphong, Quangninh, Hue, Danang, Vung tau and Hochiminh city and the respondents from online survey were 331. Printed survey was launched directly to 100 tourists in Hanoi capital and the respondents were 86. Thus, the total number of respondents collected only 417/700, and the return rate at 59.57%.

3.3. Statistical Procedure

Data was collected by the coded questionnaires and took place over 45 days. The data was recorded firstly in Excel program from 86 printed answers and 331 online answers from automatic excel in Google document. SPSS 20.0 was conducted secondly for analysing Cronbach' Alpha and EFA. The results of EFA analysing was used for structural equation modelling analysis (SEM) in AMOS 20.0 program lastly in order to test hypotheses.

4. Findings and Implication

4.1. Findings

The results show that out of 417 respondents 198(47.5%) are male and 219(52.5%) are female customers. In terms of age group, 216(51.7%) respondents has the age group of 19-40, followed by 122(29.3%) to age from 40 to 60, 59(14.4%) are above 60 and only 20(4.6%) respondents below age of 18. In terms of transport, airline route accounts for 301(72.2%) respondents, road route is at 116(27.8%). For Nationality, foreign countries (England, Australia, Taiwan, China, Singapore, Russia, Germany, Korea, Indonesia, Thailand, Laos) account for 304(72.9%) respondents and Vietnam account only for 113(27.1) respondents.

Using the Cronbach' Alpha coefficient to measure the reliability of the tourist' acceptance and intention to use e-tourism services with 4 constructs and 20 observed variables, the CronbachAlpha values of PE, PU, TA and IU are 0.871, 0.852, 0.825 and 0.806 respectively (>0.7) and the Corrected items (Total Correlation coefficient) of 20 observed variables are higher than 0.3. It can be concluded that there are 20 good reliability variables from 4 constructs because only variables with a Corrected Item (Total Correlation) greater than 0.3 and having Alpha coefficients greater than 0.6 will be accepted for analysis in the next steps (Nunnally, J. and Bernstein, I., 1994).

By conducting an EFA with the principal axis factoring of component method, the model has not reached convergence value (Table 3-Pattern matrix: first) even though KMO is high at 0.903 and sig is 0.000. Continuously removing the inappropriate variables from the model (PE7, PU3, PU7, TA3, TA4), the model is conducted at third time and the results get convergence factor at four group components (PE, PU, TA and IU) with KMO is 0.880 and sig is 0.000. In the extraction sums of squared loadings, the percentage of cumulative is 59.936% and the total of initial eigen values is 1.021.

KMO and Bartlett's Test: First					KMO and Bartlett's Test: Third				
KMO Measure of Sampling Adequacy		0.903			KMO Measure of Sampling Adequacy		0.880		
Approx. Chi-Square		4287.488			Approx. Chi-Square		3211.815		
Bartlett's Test of Sphericity df		190			Bartlett's Test of Sphericity df		105		
Sig.		0.000			Sig.		0.000		
Pattern Matrix: First					Pattern Matrix: Third				
Factor	1	2	3	4	Factor	1	2	3	4
PE1		.624			PE1	.630			
PE2		.739			PE2	.753			
PE3		.827			PE3	.834			
PE4		.718			PE4	.723			
PE5		.801			PE5	.802			
PE6		.683			PE6	.674			
PE7					PU1		.520		
PU1	.532				PU2		.649		
PU7					PU4		.709		
PU2	.720				PU5		.681		
PU3					PU6		.747		
PU4	.755				TA1			.932	
PU5	.695				TA2			.722	
PU6	.735				IU1				.873
TA1			.813		IU2				.776
TA2			.845		Extraction sums of squared loadings				
TA3			.549						
TA4					Cumulative %: 59.936				
IU1				.900	Initial Eigenvalues				
IU2				.747	Total: 1.021				

Table 2: EFA Analysis

Confirmatory factor analysis (CFA) is conducted to identify the relationship between 4 constructs and 20 observed variables and is examined two times. The results for the first running CFA show that Chi-square/df are 4.471, the covariance M.I (e1<->e2) and (e5<->e6) are high at 63.205 and 25.902. Thus, CFA is conducted the second time to adjust the absolute value by linking e1with e2 and e5 with e6. Consequently, the GFI (goodness-of-fit index), TLA, CFI (comparative fit index) are higher value than the first one.

CFI and GFI values greater than 0.90 indicate good model fit (Hu, L.T. & Bentler, P.M. , 1999). GFI values greater than 0.70 indicate good model fit (Schumacker, R.E. & Lomax, R. G., 2004). RMSEA (root mean squared error) values less than 0.06 also indicate a good model fit (Hu, L.T. & Bentler, P.M. , 1999)while values ranging from 0.08 to 0.10 indicate model fit and those greater than 0.10 indicate poor fit (Byrne, 2001). It is also observed that the RMSEA and Chi-square/df value of the second time are lower than the value of the first one. Further, all indicator variables load on highly and significantly to their respective constructs which show the model fit (Figure 2).

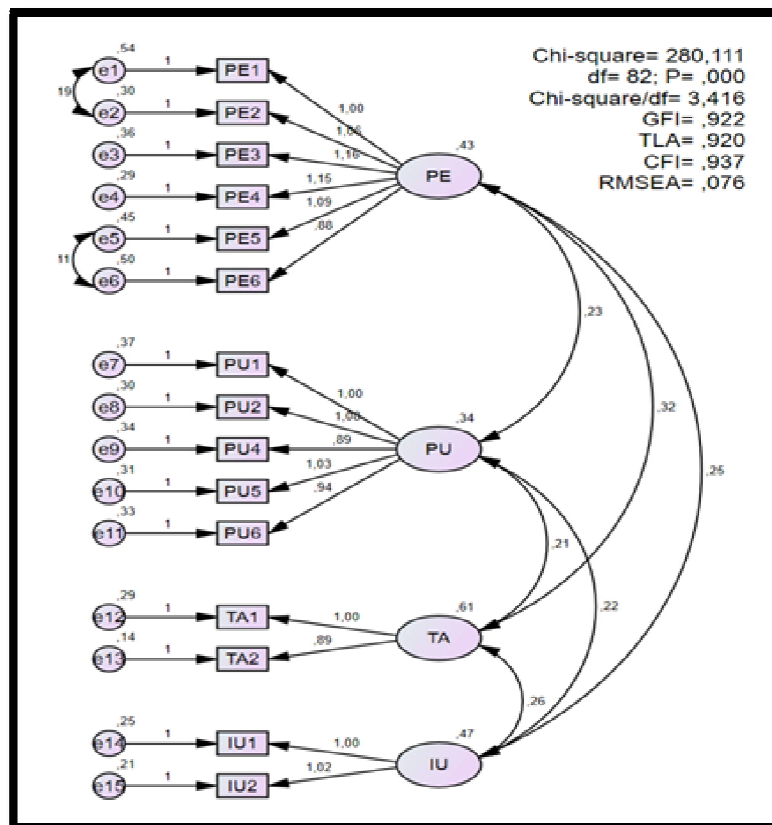

Figure 2: CFA Testing Secondly Results

Structural Equation Modelling (SEM) procedures were used to determine the impact of PE, PU and TA on IU and were also used to determine the relationship between PE and PU (H1); PE and TA (H2); PU and TA (H3); PE and IU (H4); PU and IU (H5); TA and IU (H6); PE, PU, TA and IU (H7); PE, PU and TA (H8). The results of SEM analysis are showed at Figure 3.

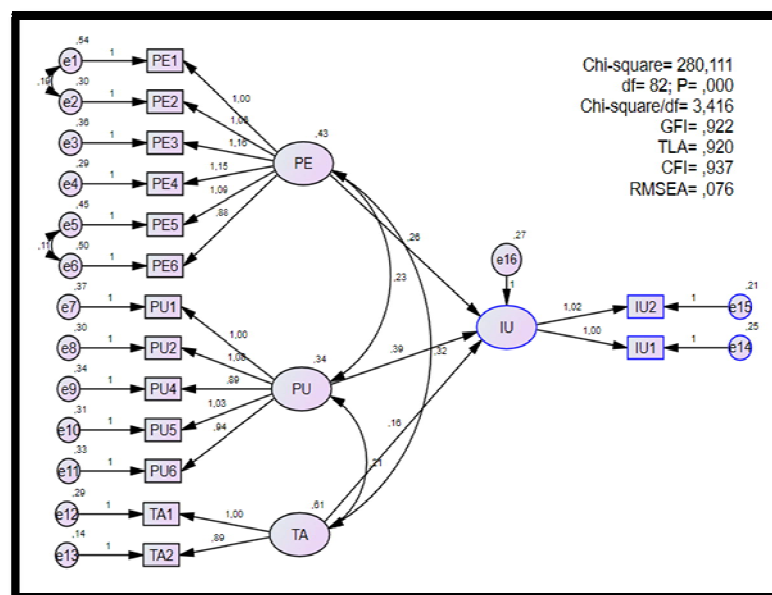

Figure 3: SEM Testing Results

The SEM showed the direct effect between TA and IU (0.162), PU and IU (0.988), PE and IU (0.258) whereas PU has strongest impact on IU. However, The SEM analysis did not show an indirect effect link from PE and TA to IU, an indirect effect link from PU and TA to IU.

The findings in Table 3 indicates that PE, PU and TA significantly and positively influence Intention to use E-tourism (IU) with Beta at 0.247, 0.331 and 0.185, p value <0.05. Thus, H4, H5 and H6 are asserted. Besides, H7 is also asserted because Intention to use is predicted positively by Perceived ease of use, Perceived usefulness and E-tourism attitude in which PU is the largest determinant on IU (Beta=0.331). Perceived ease of use has a significant and positive link with perceived usefulness (Beta=0.590, p<0.05), thus, H1 asserted. Perceived ease of use also significantly and positively affects E-tourism Attitude (Beta=0.633, p<0.05), thus, H2 asserted. Perceived usefulness significantly and positively

impacts on E-tourism Attitude (Beta=0.460, $p < 0.05$), thus, H3 asserted. Additionally, E-tourism Attitude is positively influenced by perceived ease of use and perceived usefulness, hence, H8 is asserted.

Hypothesized Path	Parameter Estimates	Regression Weights		Result Of Hypotheses
		C.R	P-value	
PE->PU (H1)	0.225	7.464	0.000	Supported
PE->TA (H2)	0.324	7.926	0.000	Supported
PU->TA (H3)	0.209	6.381	0.000	Supported
PE->IU (H4)	0.247	3.082	0.002	Supported
PU->IU (H5)	0.331	4.802	0.000	Supported
TA-> IU (H6)	0.185	2.536	0.011	Supported

Table 3: Parameter Estimates, P-Value, and Results of Hypothesis

Consequently, eight hypotheses are examined by confirming the presence of a statistically significant relationship in the predicted direction. Intention to use E-tourism is significantly and positively impact by the largest determinant Perceived usefulness on E-tourism service acceptance, following by Perceived ease of use and E-tourism attitude.

4.2. Implication

The results of the study revealed that the perceived usefulness and perceived ease of use and e-Tourism attitude are factors that directly affect tourist's intention to use e-Tourism service, whereas perceived usefulness is the strongest and most significant determinant of tourist's intention toward using e-Tourism. This means that tourists like to use e-Tourism service if they have good feelings about the usefulness of e-Tourism service in getting better journey.

The results of this study have implications that are important to different tourism stakeholders. As was discovered in this research, tourists are experienced internet users that are not worried about dealing with new technologies. Tourists mostly like to use an e-tourism service they find it useful for their journey, meaning that e-tourism service has to provide all the necessary services that a modern tourist needs in his or her journey planning. Vietnamese tourism enterprises have to develop strong and effective web service, to keep up with new web technologies and properly build them into the information system. The usefulness of an e-tourism services is also closely connected to the content of websites, online booking, and electronic payment.

First, tourism enterprises should provide full content in their website, specialized portals, electronic brochures, audio travel guides, real-time images or videos, and travel diaries through web 2.0 (youtube.com, facebook.com, pinterest.com).

Second, online bookings are mostly used in hotel area, airline and resorts. Online booking services must comply with the legal requirements which have their source in the regulations that refer to Internet services in general, and the e-commerce and distance contracting, in particular.

Third, the web of tourism enterprises should be secured strongly and provide full method of payment such as credit cards, electronic checks, digital cash. The effectiveness of e-tourism can be determined pretty fast and accurate by providing statistics, obtained through online technologies, which helps to create the profile and actions of the tourists, finally leading to a better knowledge and adaptation to the target's necessities.

Lastly, the web services like content, online booking and e-payment should be integrate into an information system. Laura et al (2009) studied the recommender system for e-tourism service in which contented four basic techniques (demographic, collaborative and content-based recommendation). They researched a recommender system in order to provide tourists with a list of information items that best fit their individual tastes. Besides, Cardoso and Lange (2007) provided a dynamic packaging as an innovative technology allowing for the automated online configuration and assembling of packaged travel products for individual customers. Thus, Vietnamese tourism enterprises have to research the suitable framework to their information system in order to highly satisfy their customers and attract more tourists.

5. Conclusion

The present study resulted in the empirical validation of the TAM research model in the context of e-tourism and therefore contributes to the body of research in the field of e-tourism service usage based on the TAM theory. The results showed that the perceived usefulness and perceived ease of use and e-Tourism attitude are factors that directly affect tourist's intention to use e-Tourism service in which perceived usefulness is the most important factor. Tourists like to use e-Tourism service because they have good feelings about the usefulness of e-Tourism service. Tourist' perceptions regarding the likeness of using the system are also reflected by their comprehensions about how easy it is to use the system. Perceived ease of use has a strong and significant impact on perceived usefulness. The SEM analysis also did not show an indirect causal link between perceived ease of use, e-Tourism attitude and intention to use e-Tourism, and not show an indirect causal link between perceived usefulness, e-Tourism attitude and intention to use e-Tourism. The tourists' intention of using e-Tourism service is mainly prompted by its perceived usefulness, meaning that tourists will use e-tourism service if they find it useful in their travel. According to the results, the actual use of e-tourism service is a result of two factors: perceived ease of use and perceived usefulness where the latter is the most significant and strongest predictor of using e-Tourism service.

In all empirical research, this study has limitations that need to be identified. First, the sample is limited to tourists. Although the results from this research are useful for describing the characteristics of a large population of

tourists, the generalizations of the results are limited to Vietnamese tourists who do not access to e-tourism service. An average tourist come from foreign countries and already possesses technical skills when it comes to internet use. In our future work, we will try to examine new variables in context of Vietnam economy development that could be used to extend the TAM model for e-Tourism service in Vietnam. Together with future information technology developments in the world, new technologies and services will enable the creation of new and innovative e-tourism system, hence here are many constructs related to the user, technology and information system. Such constructs can have a direct or indirect impact on tourists' attitudes and intention for using e-Tourism services. Our future research will therefore find and examine these constructs.

6. References

- i. Agarwal, R., Prasad, J, 1998. A conceptual and operational definition of personal innovativeness in the domain of information technology. *Information Systems Research*, 9(2), pp. 204-215.
- ii. Ajzen, I., Fishbein, M., 1980. *Understanding Attitudes and Predicting Social Behavior*. Englewood Cliffs, NJ: Prentice-Hall.
- iii. Al-Kwif, O., 2015. The impact of destination images on tourists' decision making A technological exploratory study using fMRI. *Journal of hospitality and tourism technology*, 6(2), pp. 174-194.
- iv. Autry, C.W., Grawe, S.J., Daugherty, P.J. and Richey, R.G. , 2010. The effects of technological turbulence and breadth on supply chain technology acceptance and adoption. *Journal of Operations Management*, 28(6), pp. 522-536.
- v. Buhalis D. and Law R., 2008. Twenty years on and 10 years after the Internet: The state of eTourism research. *Tourism Management Reviews*. buhalis, D., Jun, s. h., 2011. *E-tourism*. Woodeaton, Oxford: Goodfellow Publishers Limited.
- vi. Byrne, B. M., 2001. *Structural equation modeling with AMOS*. Mahwah, NJ: Lawrence Erlbaum Associates.
- vii. Cardoso J. and Lange C., 2007. A FRAMEWORK FOR ASSESSING STRATEGIES AND TECHNOLOGIES FOR DYNAMIC PACKAGING APPLICATIONS IN E-TOURISM. *Information Technology & Tourism*, Volume 9, p. 27-44 .
- viii. Chen, S.C; Liu, S.C and Li, S.H, 2013. Understanding the Mediating Effects of Relationship Quality on Technology Acceptance: An Empirical Study of E-Appointment System. *Journal of medical systems*, 37(6), pp. 1-13.
- ix. Eric, N. and Cassidy, F. Brown, L., , 2006. Exploring The Maor factors Influencing Consumer Selection of Travel Agencies in a egional Setting. *Journal of Hospitality And Tourism Management* , 13(1), pp. 26-42.
- x. Gangwar H., Date H. and Raoot A.D., 2013. Review on IT adoption: insights from recent technologies. *Journal of Enterprise Information Management*, 27(4), pp. 488-502.
- xi. Hu, L.T. & Bentler, P.M. , 1999. Cutoff criteria for fit indexes in covariance structure analysis: Conventional criteria versus new alternatives. *Structural Equation Modeling: A Multidisciplinary Journal*, Volume 6, pp. 1-55.
- xii. Iliachenko, E. Y., 2006. Customer needs with tourism websites: Tourism consumer requirements for Electronic Service Quality (E-SQ) characteristics of tourism websites, Lulea University: Department of Business Administration and social Science .
- xiii. Internetworldstat, 2017. The internet users. [Online]
- xiv. Available at: <http://www.internetworldstats.com/stats.htm> [Accessed 12 12 2017].
- xv. Jain K. and Sharma J., 2013. DRIVERS AFFECTING E-TOURISM SERVICES ADOPTABILITY. *International Journal of Advanced Research in IT and Engineering*, 2(10), pp. 87-97.
- xvi. Khasawneh, A., 2008. "Concepts and measurements of innovativeness: the case of information and communication technologies. *International Journal of Arab Culture, Management and Sustainable Development*, 1(1), pp. 23-33.
- xvii. Lallamahamood, 2007. An Examination of Individual's Perceived Security and Privacy of the Internet in Malaysia and the Influence of This on Their Intention to Use E-Commerce: Using An Extension of the Technology Acceptance Model. *Journal of Internet Banking and Commerce*, 12(3), pp. 1-26.
- xviii. Lee M.K.O, Cheung C.M.K and Chen Z., 2005. Acceptance of Internet-based learning medium: the role of extrinsic and intrinsic motivation. *Information & Management*, Volume 42, p. 1095-1104.
- xix. Lee, H.-H., and Chang, E., 2011. Consumer attitudes toward online mass customization: An application of extended technology acceptance model. *Computer Mediator Communication*, 16(2), pp. 171-200.
- xx. Legris, P., Ingham, J., & Colletette, P. , 2003. Why do people use information technology? A critical review of the technology acceptance model. *Information & Management*, Volume 40, p. 191-204.
- xxi. Lin, J.C., Lu, H., 2000. Towards an understanding of the behavioral intention to use a website. *International Journal of Information Management*, 20(3), pp. 197-208.
- xxii. Malhotra Y. and Galletta D.F, 1999. Extending the Technology Acceptance Model to Account for Social Influence: Theoretical Bases and Empirical Validation. Hawaii, Hawaii International conference on System Sciences.
- xxiii. Mokraf, M., 2013. FRAMEWORK FOR E-TOURISM DEVELOPMENT IN LIBYA. *METALURGIA INTERNATIONAL* , 8(8), pp. 161-165.
- xxiv. Murphy P., Pritchard M.P., Smith B., 2000. The destination product and its impact on traveller perceptions. *Tourism Management*, 21(1), pp. 43-52.
- xxv. Musawa, M.S. and Wahab, E. , 2012. The adoption of electronic data interchange (EDI) technology by Nigerian SMEs: a conceptual framework. *Journal of Business Management and Economics*, 3(2), pp. 055-068.
- xxvi. Ndubisi, N. O., 2006. Factors of online learning adoption: A comparative juxtaposition of the theory of planned behavior and the technology acceptance model. *International Journal on E-Learning*, 5(4), p. 571-591.
- xxvii. Nunnally, J. and Bernstein , I., 1994. *Psychometric Theory*. New York: McGraw-Hill.

- xxviii. Papińska-Kacperek, J., 2013. e-tourism Services in Polish tourists' opinions. problems of management in the 21st century, Volume 7, pp. 33-38.
- xxix. Park, S. Y., 2009. An Analysis of the Technology Acceptance Model in Understanding University Students' Behavioral Intention to Use e-Learning. *Educational Technology & Society*, 12(3), p. 150-162.
- xxx. Pavlou, P., 2003. Consumer acceptance of electronic commerce: Integrating trust and risk with the technology acceptance model. *International Journal of Electronic Commerce*, 7(3), pp. 101-134.
- xxxi. Phutela N. and Dasgupta H., 2014. STUDY ON FACTORS INFLUENCING CONSUMER TRUST FOR E-TOURISM COMPANIES IN INDIA. *Abhinav National Monthly Refereed Journal of Research in Commerce & Management*, 3(9), pp. 24-343.
- xxxii. Porter, C.E., Donthu, N., 2006. Using the technology acceptance model to explain how attitudes determine Internet usage: The role of perceived access barriers and demographics. *Journal of Business Research*, 59(9), pp. 999-1007.
- xxxiii. Rouhani S., Ravasan A.Z, Hamidi H. and Vosough S., 2013. Identification and Classification of Affecting Factors on E-Tourism in Iran. *Middle-East Journal of Scientific Research*, 16(10), pp. 1361-1368.
- xxxiv. Schillewaert, N., Ahearne, M.J., Frambach, R.T. and Moenaert, R.K., 2005. The adoption of information technology in the sales force. *Industrial Marketing Management*, 34(4), pp. 323-336.
- xxxv. Schumacker, R.E. & Lomax, R. G., 2004. *A beginner's guide to structural equation modeling*. New Jersey: Lawrence Erlbaum Associates.
- xxxvi. Sebastia L., Garcia I., Onaindia E., Guzman C., 2009. e-TOURISM: A TOURIST RECOMMENDATION AND PLANNING APPLICATION. *International Journal on Artificial Intelligence Tools*, 18(5), p. 717-738.
- xxxvii. Smith, S., 1994. The Tourist Product. *Annals of Tourism Research*, 21(3), pp. 582-595. statistics, T., 2015. Domestic visitors (2000 – 2015). [Online]
- xxxviii. Available at: <http://vietnamtourism.gov.vn/english/index.php/items/10259>
- xxxix. [Accessed 1 8 2017]. statistics, T., 2017. International visitors to Viet Nam in October and 10 months of 2017. [Online]
- xl. Available at: <http://vietnamtourism.gov.vn/english/index.php/items/12282>
- xli. [Accessed 1 8 2017].
- xlii. Stockdale, R., 2007. Managing customer relationships in the self-service environment of e-tourism. *Journal of Vacation marketing*, 13(3), pp. 205-211.
- xliii. Teo, T., Luan, W.S., Sing, C.C., 2008. A cross-cultural examination of the intention to use technology between Singaporean and Malaysian pre-service teachers: An application of the Technology Acceptance Model (TAM). *Educational Technology and Society*, 11(4), pp. 265-280.
- xliv. UNWTO, 2017. *Tourism market trends*, World Tourism Organization: UNWTO.
- xlv. UNWTO, 2017. *UNWTO tourism highlights*, NY: UNWTO.